



East Asia School of Theology

Prospectus 2009

TABLE OF CONTENTS

TABLE OF CONTENTS	3
GENERAL INFORMATION	5
HISTORY AND PHILOSOPHY	6
MISSION	6
VISION	6
CAMPUS AND FACILITIES	6
DECLARATION OF COMMITMENT TO EXCELLENCE	6
PRIORITIES AT EAST	7
ACCREDITATION AND AFFILIATION	8
STUDENT ADMISSIONS	9
GENERAL ADMISSION REQUIREMENTS	10
ADDITIONAL REQUIREMENTS (INTERNATIONAL APPLICANTS)	10
APPLICATION PROCEDURE	10
ACCEPTANCE PROCEDURES	12
HOUSING	13
REGISTRATION	13
MEDICAL INSURANCE	13
ACADEMIC TRACKS	14
ACADEMIC POLICIES	15
CLASS CREDITS AND GRADES	16
TIME LIMITS ON DEGREE PROGRAMMES	17
ACADEMIC STATUS	17
TRANSFER OF CREDIT	17
STUDENT STATUS	18
CONFIDENTIALITY OF STUDENT DATA	18
FIELD EDUCATION AND STUDENT LIFE	19
PHILOSOPHY OF THE FIELD EDUCATION PROGRAMME	20
FIELD PRACTICUM	20
F.I.R.M CLASSES	20
CROSS CULTURAL INTERNSHIP/ VOCATIONAL INTERNSHIP	21
STUDENT LIFE	21

FINANCIAL INFORMATION	23
TUITION FEES AND EXPENSES	24
ADDITIONAL EXPENSES FOR FOREIGN STUDENTS	26
PAYMENT OF FEES	27
FINANCIAL AID	27
SCHOLARSHIP	28
ACADEMIC PROGRAMMES	29
INTRODUCTION	30
MASTER OF DIVINITY PROGRAMME	31
MASTER OF ARTS IN BIBLICAL STUDIES	33
MASTER OF ARTS IN INTER-CULTURAL STUDIES	35
GRADUATE CERTIFICATE	37
BACHELOR OF ARTS IN CHRISTIAN MINISTRY	42
CLASS DESCRIPTIONS	45
CLASS DESCRIPTION KEY	46
CLASS NUMBERING SYSTEM	46
BIBLICAL & LANGUAGE STUDIES (BLS)	47
THEOLOGICAL & HISTORICAL STUDIES (THS)	49
INTER-CULTURAL STUDIES (ICS)	51
LEADERSHIP, MINISTRY & COMMUNICATION (LMC)	52
PASTORAL COUNSELLING (PCM)	57
PERSONNEL	59
RESIDENT FACULTY	61
ADJUNCT FACULTY	64
STAFF	66
APPENDICES	67
DOCTRINAL STATEMENT	68
ESTIMATED COST OF PROGRAMME FOR FULL-TIME STUDENTS	70
SCHOOL CALENDAR	71



GENERAL INFORMATION

EAST reserves the right to change without notice any statement in this prospectus concerning, but not limited to rules, policies, tuition, fees, faculty, curricula, and classes.

HISTORY AND PHILOSOPHY

East Asia School of Theology (EAST) was established by Campus Crusade Asia Limited in 1992. The school is committed to providing men and women with a Christ-centered theological education and to equip them for ministry. EAST has graduated over 150 Christian leaders. About 95 percent of them are actively serving in diverse mission fields in Asia, Africa, America, Australia, and Europe.

MISSION

The mission of EAST is to develop and equip Christian leaders for the fulfilment of the Great Commission in East Asia and around the world. The school equips Christian leaders to be passionate spiritual multipliers committed to growing in Christ-likeness, learning and living out God's Word, and communicating God's Word effectively.

EAST accomplishes this mission by integrating academic training with practical ministry in a community of care and mentoring, and by emphasizing field education, internship, and classroom teaching/training.

VISION

EAST is committed to be a theological school of excellence that develops biblically-grounded leaders of spiritual movements for the global harvest.

CAMPUS AND FACILITIES

EAST is located on 1 Dorset Road, Singapore 219486. The school is within the compound of Parish of Christ Church. It can accommodate a total enrolment of 100 students. There are four air-conditioned classrooms with wireless internet access. Each classroom can seat 20-25 students and the chapel is big enough for 80 people.

The library is located on level three of Christ Church's administrative block. At present, the library has more than 12,000 titles and 65 periodical titles. It is fully computerized with wireless access for every user. There are also computers and laser printers in the library designated for student use.

The Administrative Office is open from 9:00 am to 5:00 pm, Monday to Friday.

DECLARATION OF COMMITMENT TO EXCELLENCE

By the grace of God the faculty and staff of EAST commit themselves to:

1. Live godly lives and be above reproach as required of leaders by the Scriptures.
2. Model a love for God and His Word and a commitment to His authority over our lives.
3. Emphasize the integration of academics, character development, and ministry involvement.
4. Provide an environment that will help students develop as spiritual multipliers.
5. Demonstrate academic integrity and excellence by thorough preparation and effective communication of relevant information.

PRIORITIES AT EAST

In order to accomplish the mission of EAST, the school provides an educational experience that places high priority on the following values:

Transformation of life

The goal of the EAST experience is to see personal transformation and growth in the life of the student. Underlying all that we do is the purpose of equipping our students with a solid biblical foundation of knowing God and His Word: “Be transformed by the renewing of your mind...” (Rom. 12:2). We believe that Christian ministry should spring from the overflow of a vital and intimate relationship with God. Therefore, the development of the character traits and biblical convictions found in 1 Timothy 3 and Titus 1 are emphasized both in the classroom and in ministry situations.

Integrated Education

In order to develop effective disciple-makers and leaders of spiritual movements, EAST helps each student develop an effective personal ministry so that he/she can integrate biblical truths and ministry skills in situations similar to those that he/she may encounter after graduation. There is thus an emphasis on the student’s field education experience. The development of each student’s ministry is monitored and evaluated to help him/her sharpen his/her ministry abilities. Our desire is that each student will be able to master skills of evangelism, discipleship, and other leadership skills that would enable to be an effective spiritual leader.

Community Life

EAST seeks to develop an environment that promotes growth through caring interpersonal relationships, accountability, encouragement, and acts of grace, forgiveness and kindness. This is only possible when there is a shared commitment to apply biblical truths concerning how we should relate to one another in the community of faith. The student body comprises students from different nations representing different cultures of the world. Each student brings with him/her his/her unique cultural experience that creates challenges for cross-cultural adjustments, yet this also enriches the overall learning experience for the community.



Mentoring and modelling by Faculty

EAST is committed to a mentoring model of education. In order to develop a strong relationship between students and faculty, the student/faculty ratio is kept low. Faculty members serve as mentors to their students, teaching and modelling a lifestyle that demonstrates faith in God, a deep walk with God, ministry proficiency, godly character, and academic excellence. Every resident faculty member, for example, models faith as a missionary teacher by trusting God to provide for his/her needs through raising his/her own finances.

Global Vision for the Great Commission

EAST aspires to develop in each student a passion and vision for reaching the world for Christ. In collaboration with mission organizations and local churches, EAST continually exposes its students to the global harvest field. Through interaction with missionaries, sharing of field experiences, regular prayer times for missions, and missions assignments and course work, students have their vision enlarged and their burden for the harvest field deepened.

Equipping of Spouses

EAST considers the spouses of its students to be partners in ministry. There is an emphasis of this familial commitment to the Lordship of Jesus Christ and to Christian service. We therefore seek to equip married couples to work together as a team while in seminary in preparation for a lifetime of ministry together upon graduation. The Partners-in-Ministry programme is designed to encourage spouses to grow in biblical knowledge, Christian character, and ministry skills. As the spouses of our students grow, they will be better able to complement the students' ministries and the overall effectiveness of the family is enhanced.

ACCREDITATION AND AFFILIATION

The East Asia School of Theology has been operating with the approval of the Ministry of Education of the Republic of Singapore since August 1992.

EAST is accredited by the Asia Theological Association (ATA) to offer the Bachelor's and Master's degrees.

EAST is also accredited by the Association for Theological Education in South East Asia (ATESEA) to offer the Master of Divinity Degree.

In addition, EAST is a member of the International Leadership Consortium (formerly the International Schools of Theology), a network of leadership development institutions.

EAST has been awarded CaseTrust for Education for good business practices (Serial no: CT/0388) since 8 January 2006. However, as EAST is an institution for religious studies, CaseTrust has granted EAST exemption since January 2007.



*STUDENT
ADMISSIONS*

GENERAL ADMISSION REQUIREMENTS

EAST considers each applicant's qualifications in these five areas:

1. Maturity (personal, social, and spiritual)
2. Ministry experience
3. Leadership ability
4. Academic ability
5. Academic entry requirement (see Academic Tracks):
 - a. A bachelor's degree from an accredited or recognized university or college for admission to a master's programme or graduate certificate programme.
 - b. An A-level certificate or diploma from a recognized tertiary institution for admission to Bachelor of Arts in Christian Ministry.

Note: EAST reserves the right to make exceptions to the above policy.

ADDITIONAL REQUIREMENTS

(INTERNATIONAL APPLICANTS)

1. Proficiency in the English Language

Students whose first language is not English are required to take the Test of English as a Foreign Language (TOEFL) or a comparable test of English proficiency prior to acceptance. It is the responsibility of the applicant to take the test and to arrange for the scores to be sent to EAST, Office of Admissions. For admission to a degree programme, EAST requires a TOEFL score of not less than 76 on the Internet-Based Test (IBT) or 207 on the Computer-Based Test (CBT) or 540 overall or 53 minimum on each of the three sections of the Paper-Based Test (PBT).

2. Financial Guarantees

Proof of financial support from a sponsoring church (letter of sponsorship) or individual (bank statement) must be produced. The school provides an estimate of education and living expenses for international applicants.

APPLICATION PROCEDURE

All applicants are required to send a completed application form to:

Admissions Office
East Asia School of Theology
1 Dorset Road
Singapore 219486

For enquiries, please contact EAST office at:

Tel: (65) 62919744

Fax: (65) 62995040

Email: admissions@east.edu.sg

Website: <http://www.east.edu.sg>

Together with the completed set of application forms, the applicant must submit the following items:

1. **Applicant's photographs:** paste one recent passport sized photograph on the right hand corner of the application form and submit another photograph.
2. **Personal Documents of Identification.** Submit a photocopy of the NRIC for Singaporeans and passport for foreign students.
3. **Application Fee**
Applicants have to pay a S\$60 or US\$45 non-refundable application fee for each degree programme or certificate programme. Cheques, money orders, or drafts should be made payable to "East Asia School of Theology."
4. **Biographical Summary**
This covers conversion, call, ministry experience, and the reasons for pursuing theological education at EAST.
5. **Official Transcripts and Certificates**
This includes ALL certificates and transcripts earned from educational institutes beyond secondary or high school ('O' level). It is preferred that the applicant's previous schools send the original transcripts directly to EAST or that the originals be brought to EAST for verification.
6. **Character References**
Four references are required. These should include a pastor or church leader who knows the applicant well and a direct supervisor if he/she is in a vocational ministry position. The other three references may include a friend, a teacher or a professor, a colleague, or former employer who knows the applicant well. Spouses and relatives are not acceptable references. The names and full addresses of all the references should be written on the application forms so that EAST will know from whom to expect the reference forms.

The applicant should give the reference form together with a stamped envelope addressed to EAST to their reference. The reference should send the completed reference form directly to EAST, not to the applicant, in a sealed envelope.

Note: The Admissions Office will not consider applications that do not have the required documents mentioned above. All completed applications (with application fee and accompanying documents) must reach EAST four months before the start of the quarter for international students (three months for local students). The entire admission process normally takes four to eight weeks once all the required documents are received. The Admissions Office will inform the applicants the results of their application.

ACCEPTANCE PROCEDURES

1. Upon receiving the letter of offer, the student needs to send the school an acceptance fee of \$50 or US\$35 (non-refundable) as an acknowledgement of their acceptance of the offer within 21 days. This fee will be credited to the tuition fees when the student registers for classes.
2. International students need to submit this fee together with their completed student pass application forms (which can be downloaded from www.ica.gov.sg).
 - a. The prospective student needs to submit the following forms and documents to EAST:
 - i. One original copy of each of the Forms 16, V36, V39S.
 - ii. Passport pages showing full particulars including passport expiry date (photocopy).
 - iii. Birth certificate (notarized and translated if not in English). Both notarized and translated birth certificates must be submitted.
 - iv. Marriage certificate if the student is married (notarized and translated if not in English). Both notarized and translated marriage certificates must be submitted.
 - v. Educational certificates and transcripts (notarized and translated if not in English). Both notarized and translated educational certificates and transcripts must be submitted.
 - b. The student pass application forms must be returned properly filled and signed. The school will not process incomplete forms or documents. Student pass applicants are hereby cautioned that it is an offence under the Immigration Act to submit false statements, representations, or declarations in their student pass application forms.
 - c. EAST will e-submit the completed student pass application to the Immigration Checkpoint Authority (ICA) on behalf of the prospective students via the SOLAR+ system. It takes the ICA about 4-8 weeks to process the application.
 - d. EAST will liaise with the prospective student on e-payment of \$30 processing fee to ICA.
 - e. When the student pass is approved, the Admissions Office will notify the new student to come to Singapore as soon as possible.
 - f. NOTE: The new student must bring with him/her ALL original documents to be presented to the ICA for verification.

HOUSING

Foreign students are encouraged to arrive early to secure housing, obtain a student pass, and get settled in Singapore before the start of classes. On-campus housing is not provided. However, notices of available housing are usually posted at the notice boards on levels 3 and 4 of the school building and in the library. The Admissions Officer and the Student Council will assist first year foreign students to look for suitable accommodation.

REGISTRATION

Upon acceptance into a study programme, the new student will receive information for class registration. He/she will also receive a copy of the Student Handbook during the Orientation week.

All new students begin their time at EAST with a week of orientation. This is usually held one week before the first day of school in the new academic year. The orientation programme is compulsory for all students. It is designed to help students get registered and be acquainted with the various aspects of student life at the school. Special workshops are conducted for international students to assist them in their cross-cultural adjustments to living in Singapore. Organised bonding activities seek to help the new students, returning students, staff and faculty get to know one another.

MEDICAL INSURANCE

EAST requires all foreign students to have medical insurance coverage. The school offers students and their family members, who are living in Singapore, an insurance coverage through SCCC at a discounted rate. If the student has an existing insurance policy that does not cover Singapore, he/she must be enrolled in the medical insurance plan offered by EAST.

If the student's existing policy has international coverage, he/she will need to sign the Health Insurance Waiver Form (obtainable from the Registrar's Office). The student also needs to submit a photocopy of the insurance plan to the Registrar Assistant.

ACADEMIC TRACKS

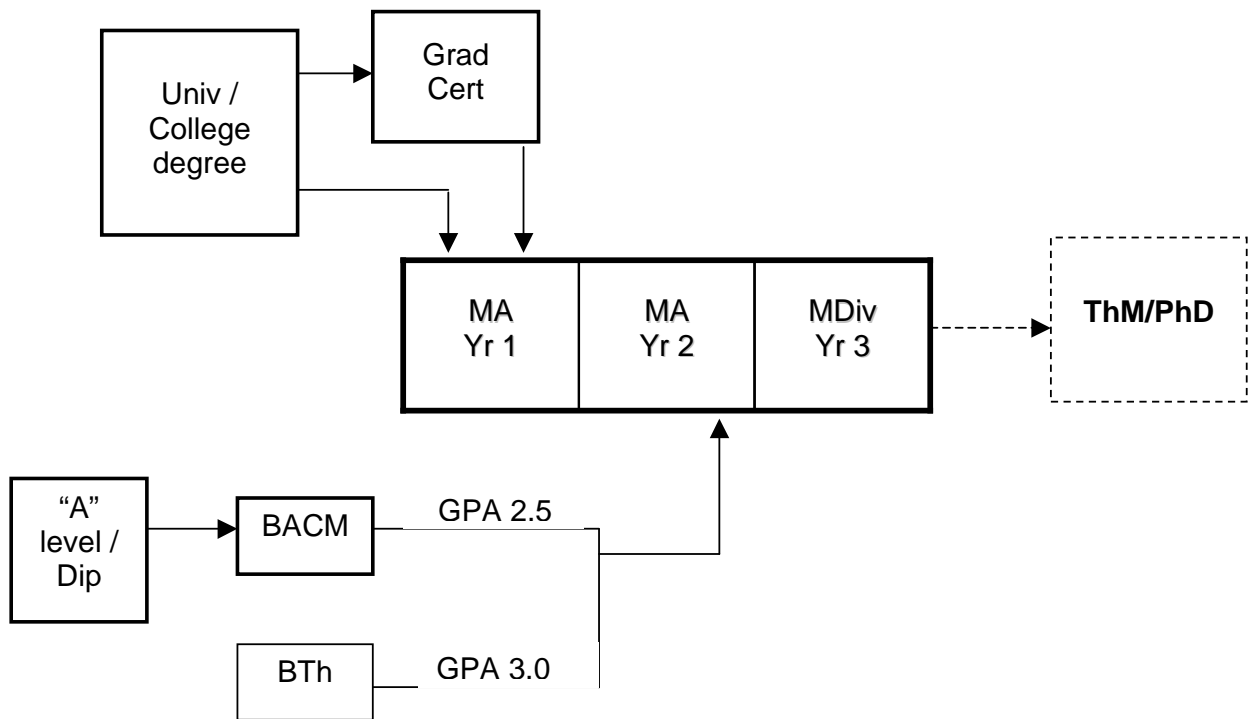



CLASS CREDITS AND GRADES

Class credits are based on the quarter credit-hour system. Each credit represents approximately 10 hours of classroom work and 15-20 hours of homework and out-of-classroom involvement. Classes are either two credits or four credits. Many classes also involve application in ministry situations as part of the out-of-classroom involvement.

The following criteria determine class credit:

1. A grade of A, B, C, or S is necessary to receive credit toward a master's degree or graduate certificate.
2. A grade of A, B, C, D, or S is necessary to receive a credit toward a bachelor's degree.
3. A grade of A, B, C, D, S, or P is necessary to receive credit toward a Partners-in-Ministry certificate.
4. If a student is unable to complete his/her class work due to death or sickness in the immediate family, an Incomplete (I) will be given. If the student has not made up the class work within 30 days of the last class session, the "I" will be changed to either a passing grade calculated considering zero marks for the missing work or a "No Credit" if the grade would not be a passing grade.

A student who does not complete his/her class work for other reasons and who would not receive a passing grade without completing the missing work may be given an Incomplete at the teacher's discretion. The student has 30 days or less, as determined by the teacher, to complete the work or receive a non-passing grade.

Grading System

Students will receive a grade for each class taken for credit. The grades are as follows:

<u>Grade</u>	<u>Grade Points</u>	<u>Significance</u>
A	4.0	
A-	3.7	EXCELLENT
B+	3.3	
B	3.0	GOOD
B-	2.7	
C+	2.3	
C	2.0	FAIR
C-	1.7	
D+	1.3	
D	1.0	POOR
D-	0.7	
F	0	FAILURE
S	-	CREDIT (degree & graduate certificate)
P	-	CREDIT (non-degree certificate)
NC	-	NO CREDIT
W	-	WITHDRAWN
I	-	INCOMPLETE classification

A recorded grade will not exceed an "A" or 4.0. Grades are determined by homework, papers, class work, field work, quizzes, and final examinations.

Class Assignments

A student is expected to spend approximately 1½ to 2 hours doing homework assignments for each hour spent in class. The homework grades are part of the final class grade and may be reduced up to one letter grade if turned in late.

TIME LIMITS ON DEGREE PROGRAMMES

The time limits for completion of the various programmes are as follows:

1. Seven years for the Master of Divinity degree.
2. Five years for a Master of Arts or Bachelor of Christian Ministry degree.
3. Five years for the Graduate Certificate.

The time limit starts from the date the student begins studies at EAST after having been accepted into the respective degree programmes. A student must officially apply for a leave of absence from his/her programme and seek approval from the school. The school may grant a leave of absence for a total of two years to an MDiv student and one year for an MA and BA student.

Students desiring to complete their programmes of studies within the stipulated time (see individual programme description), should follow the sequencing of classes offered by the school as much as possible.

ACADEMIC STATUS

To graduate from any master's degree or graduate certificate programme, a student must obtain at least a cumulative grade point average (GPA) of 2.5 or higher. Graduating from a bachelor's degree programme requires a GPA of 2.25 or higher. Students are placed on academic probation when their cumulative average falls below the required grade. Any student whose GPA falls below 2.0 for any quarter will be asked to leave the programme.

Students will remain in good standing with the school if they conduct themselves with spiritual and moral integrity, maintain the required GPA, and meet their financial obligations to the school. The administration reserves the right to dismiss any student whose academic, spiritual, moral, or financial integrity is unsatisfactory.

TRANSFER OF CREDIT

Transfer of credit is accepted from other graduate level or bachelor level institutions of recognized standing where work parallels that of classes in the EAST curriculum or where classes legitimately fit into one of the EAST degree programmes. Transfer of credit is accepted upon review of the Registrar and approval of the Dean of Academics. No class will be transferred with a grade lower than "B" or GPA 3.0, or equivalent.

Transferred credits having fewer hours than EAST classes will be given the value at which the classes were taken but those having more hours than EAST classes will be given the value at which EAST offers them. A student may transfer up to a maximum of 50% of the total credits of the programme he/she is applying for. The student's final GPA at EAST will not include transferred credits except those from the other accredited schools in the International Leadership Consortium (formerly ISOT Consortium).

In order to transfer credit, an official transcript must be sent to the Registrar directly from the institution where the student received previous graduate credit. The student may also be required to provide a catalogue, syllabus or class notes from the previous institution if deemed necessary. Credit will not be accepted if a student has been academically dismissed from an institution.

Students who wish to take credit classes elsewhere during their course of study at EAST should seek prior approval from the Registrar and the Dean of Academics.

Advanced Standing

A graduate with a bachelor's degree in theology (BTh) from an accredited institution may be granted exemption up to one year from the master's program at EAST.

STUDENT STATUS

Students at EAST are either programme students or visiting students. Those who are not officially accepted into a programme at EAST are considered visiting students. They may be auditing or even be taking classes for credit.

Programme students should take a minimum of 18 credits per year (or an average of 6 credits per quarter) in order to complete their degree programme within the specified time period. This does not include Field Practicum and Internship.

Note: Visiting students can take up to a maximum of 20 credits. Thereafter they are encouraged to apply for a degree programme. However, students may continue to audit classes.

CONFIDENTIALITY OF STUDENT DATA

EAST is committed to maintaining the confidentiality of the student's personal information. Subject to approval by the Registrar and/or Principal, faculty, and staff may review the student's file and academic record when legitimate academic interests require it. The school does not supply directory information indiscriminately to commercial concerns for the purpose as mailing lists. EAST undertakes not to divulge any of the student's personal information to any third party without the written consent of the student.

The confidentiality undertaking has the following exceptions: 1) Appropriate information is released to medical personnel when the health of the student or others would be endangered by the withholding of information. 2) Specific data is given to the relevant authorities for government related matters or accreditation purpose.

*FIELD
EDUCATION &
STUDENT LIFE*



PHILOSOPHY OF THE FIELD EDUCATION PROGRAMME

The philosophy of the field education programme is to allow students not only to experience varied field ministries and exposures in a supervised environment but also to have time for personal spiritual formation, integration, and reflection. With the aid of objective evaluation and feedback, as well as seeing ministry modelled by their supervisors, the students are able to integrate classroom knowledge into practical ministry experience. The field experience in turn builds a greater motivation and hunger for further instruction and training.

The field education programme, including classes in evangelism and discipleship, is designed to equip students to become a *Reproducer* (one who can witness and disciple another to do likewise), a *Multiplier* (one who can disciple others and train more to do likewise), and an *Influencer* (one who can use their God-given gifts and talents to influence others positively in Christ).

Field education comprises three main components: (1) Field Practicum; (2) Formation, Integration, Reflection, and Ministry (F.I.R.M.) classes; (3) Cross-Cultural Internship/Vocational Internship.

Field Practicum

All students, except first year students, are expected to spend about 8 hours per week in field practicum in churches or mission agencies. This time should be devoted to ministry, both to Christians and non-Christians. As such, students may expect some adjustments to their present church/ministry responsibilities in order to fulfil field practicum requirements.

Field practicum will be under the direct supervision of a field supervisor from the participating church/mission agency. However, the overall direction and leadership will be provided by the Field Education Director at EAST.

Formation, Integration, Reflection, and Ministry (F.I.R.M.) Classes

In line with EAST's desire to provide integration, application, and personal development in its programmes, all students are required to participate in the Formation, Integration, Reflection, and Ministry (F.I.R.M.) classes while undergoing their field practicum. As the name suggests, F.I.R.M. seeks to complement the spiritual and field direction given by the field supervisors as well as the theological integration and reflection offered by the spiritual supervisors in the school. It allows students to deliberately and temporarily disengage from all academic studies and ministry involvements in order to reflect on their personal growth and walk with God. Ultimately, through F.I.R.M., EAST hopes not just to produce good ministers and academicians but well integrated disciples of Christ.

Cross-Cultural Internship/ Vocational Internship



Cross-cultural internship takes place during any of the vacation breaks in the student's study. Students spend at least four weeks in a cross-cultural or multicultural setting working primarily in (but not limited to) evangelism and discipleship. The internship is intended to help the student gain a heart and personal vision for missions, provide exposure to and experience in living and ministering in a cross-cultural context so that the student will consider serving God in a cross-cultural ministry.

Vocational internship is a requirement for all Master of Arts programme at EAST. It takes place during any of the vacation breaks in the student's study. Students spend at least four weeks working under the supervision of a professional Christian worker for the particular vocational emphasis that the student is pursuing.¹ For example, students who are in the Biblical Studies track may use the internship to develop a special biblical study project under the supervision of a Bible scholar or teacher. Vocational internship may be done locally or overseas in a cross-cultural environment.

STUDENT LIFE

Orientation

At the beginning of each academic year, the returning students, under the direction of the Student Council will host an orientation for all new students. The purpose of the orientation is to help all staff as well as students at EAST get to know one another and to be briefed or updated on the school policies. Traditionally, the orientation promises to be a time of fun, laughter, friendship, food, inspiration, and even education. Attendance at the orientation is compulsory for everyone.

Spiritual Supervision

All programme students at EAST will be assigned a spiritual supervisor as part of EAST's value to mentor our students and help develop their character. The Spiritual Supervisor meets with the student informally on a regular one-to-one basis and during the Family Group time in order to provide spiritual direction and formation and guide the student in his/her life, relationships, studies, and ministries. The overriding concern is the character development of each student.

Family Group Time

All programme students are assigned to a Family Group with a Spiritual Supervisor. Each group is led by a student who is appointed by the Spiritual Supervisor. The purpose of the Family Group is to provide the student a community for encouragement, accountability, and growth. Besides the official Family Group times scheduled during school time, group members also meet informally outside school, at home, etc.

¹ The exception being the Master of Arts in Pastoral Counselling which vocational internship requirement is 8-10 weeks.

Chapel

Chapel is an important component of the EAST experience. It seeks to help students grow in their spiritual life through worship, prayer, and service within a community of believers. All full-time students are expected to attend the weekly Chapel since it is also viewed as an integral part of the field education programme.

Prayer Time

Prayer is another important discipline that EAST hopes to cultivate in the students. Students are encouraged to form prayer groups and to utilize the prayer tower in the school. A time for prayer often takes place toward the end of the Chapel service. Students are encouraged to submit updated praise and prayer items to the Prayer Coordinator for intercession by the entire school.

The Worldwide Day of Prayer is held twice a year, during which the entire day is devoted to prayer for the needs of different countries around the world.

Community Outreach and Witnessing

EAST's heritage derives from a ministry that is born out of the desire to obey Christ's Great Commission. As such, the students and Family Groups are encouraged to organize and be involved in regular community outreaches, personal witnessing, and discipleship.

Fellowship and Recreation



To cultivate the family bond among the EAST family, fellowship lunches, and other special fellowship functions involving faculty, staff, and students are organised periodically. Get-togethers may also be organized on an ad-hoc basis with professors by their respective classes.

The student-maintained Agape Room offers both students and their families a place to rest, relax, chat, and eat together. After a hard day of study, students may also unwind with a game of table tennis at the Recreation Room, or a game of tennis at the nearby Farrer Park tennis courts, or a swim at the nearby swimming club. Inter-collegiate games are organised once a year with other seminaries in Singapore to foster closer fellowship among the theological community.



*FINANCIAL
INFORMATION*

TUITION FEES AND EXPENSES²

EAST desires to provide quality theological education for all its students. Tuition charges paid by the students only cover a portion of the actual costs of the education. The school depends on gifts and grants from friends, corporations, churches, and other Christian organizations to provide the balance of the operating costs. All expenses itemized in the table below are estimates for one person (unless noted otherwise) and are subject to change.

Application Fees (one time, non-refundable)

Degree/certificate student	S\$60.00 (US\$45.00)
PIM student	S\$30.00 (US\$20.00)

Programme Student/Alumni/Spouse of Student Tuition Fees³

Credit	S\$62.00 per credit
Audit	S\$31.00 per credit
Refresher	S\$25.00 per credit
Foundational credits	S\$31.00 per credit

Partners in Ministry (PIM) Class Tuition Fees³

Spouse of Programme Student	S\$31.00 per credit
Spouse of Non-Programme Student	S\$48.00 per credit

Visiting Student Tuition Fees³

Credit	S\$80 per credit
Audit	S\$40 per credit

Other Fees Pertaining To All Categories

New student acceptance fee (non-refundable) ⁴	S\$50.00 (one time)
Registration fee per quarter	S\$27.00
Orientation/Student activity fee per quarter	S\$33.00
Class material fee	S\$ 6.00 per 2 credit
Add/drop/change/withdraw fee	S\$11.00 per class
Late registration fee	S\$22.00
Late payment fee	S\$11.00

Graduation Fees

Master's/Bachelor's degree student	S\$268.00
Graduate certificate student	S\$236.00
PIM Certificate	S\$107.00
Transcript: 1 st copy	FREE
Subsequent copies	S\$22.00 ⁵
Certificate: 1 st copy	FREE
Duplicate copies	S\$22.00 ⁵

² All fees are rounded to the nearest higher dollar after inclusion of the Singapore Goods and Services Tax (G.S.T.). The current G.S.T. rate is 7%. The below fee structure shall take effect from October 5th, 2009 (2nd Quarter of 2009/10) onwards.

³ All tuition fees are subject to approximately 5% increment annually to take into account inflation.

⁴ This fee will also be used as an advance deposit to offset the new student's school fees upon registration for classes.

⁵ For overseas registered mail, a fee of S\$10.00 will be included in addition to the transcript charges.

Term report: 1st copy
 2nd copy
 Subsequent copies

FREE
 S\$3.00⁵
 S\$5.00⁵

Drop and Add Charges

A student has to fill out an Add/Drop Form if he/she wants to add or drop a class or change from credit to audit or vice versa. He/she needs to get the required signatures and submit the form to the Registrar. There is a S\$11.00 charge for every change made after the closing dates for registration for each quarter. Students are not required to pay the S\$11.00 add/drop fee if the school cancels a given class.

If a student drops a regular class during the first week of school (or before the second day of an intensive class), 100% of the tuition fee for that class is refundable. The charts on the following page show the deadlines, policies and fees for dropping, adding, withdrawing, or changing classes.

	ADD A CREDIT CLASS	ADD AN AUDIT CLASS	DROP A CREDIT OR AUDIT CLASS
REGULAR CLASS PROGRAMME STUDENTS	During the 1st week S\$11.00 per add	During the 1st 2 weeks S\$11.00 per add	During the 1st 2 weeks S\$11.00 per drop <i>1st week 100% tuition refund</i> <i>2nd week 50% tuition refund</i>
INTENSIVE CLASS PROGRAMME STUDENTS	Before the 2nd day S\$11.00 per add	Before the 3rd day S\$11.00 per add	Before the 3rd day S\$11.00 per drop <i>Before the 2nd day 100% tuition refund</i> <i>Before the 3rd day 50% tuition refund</i>
VISITING STUDENTS	Same as above except late fee may apply	Same as above except late fee may apply	Same as above for regular and intensive classes

Withdrawal

Withdrawal is dropping out of a regular class AFTER the 2nd week of class or after the third day of an intensive (block) class. “W” for withdrawal will appear on a student’s transcript. A “W” does not add to or remove any marks from the grade point average. “W” will be removed when the class is re-taken. For a student who has not withdrawn by the deadline, whatever grade he/she receives, including “D” (“Poor”) or “F” (“Fail”), will appear on the student’s transcript and will affect the student’s grade point average.

	CHANGE FROM AUDIT TO CREDIT	CHANGE FROM CREDIT TO AUDIT	WITHDRAW FROM A CREDIT CLASS
REGULAR CLASS PROGRAMME STUDENTS	During the 1st 3 weeks With the teacher’s permission S\$11.00 per change (<i>Pay the tuition difference</i>)	During the 1st 5 weeks S\$11.00 per change	By the 6th week S\$11.00 per change <i>No tuition refund</i>
INTENSIVE CLASS PROGRAMME STUDENTS	Before the 4th day With the teacher’s permission S\$11.00 per change <i>Pay the tuition difference</i>	During the 1st week S\$11.00 per change	By the end of the first week S\$11.00 per change <i>No tuition refund</i>
VISITING STUDENTS	Same as above	Same as above	Same as above

ADDITIONAL EXPENSES FOR FOREIGN STUDENTS

- All foreign students (and their immediate family members who will be coming to Singapore) are required to have health insurance coverage which will cover their hospitalization expenses in Singapore. Students may sign up for health insurance for themselves and their dependants who are in Singapore through Campus Crusade for Christ’s corporate policy at an estimated yearly premium of S\$300-\$500.
- All foreign students (except Malaysians) are required to raise a Security Deposit before they can obtain their Student Passes. The amounts are:

Banker’s Guarantee Deposit (refundable upon completion of their study):

Nationals from Indonesia, Philippines, and Thailand	S\$1,000
Nationals from Bangladesh, Myanmar, People’s Republic of China, and India	S\$5,000
Others	S\$1,500

Banker’s Guarantee Commission	[S\$10/mth] S\$350-S\$370
-------------------------------	------------------------------

- Immigration Fees

Student Pass/Social Visit Pass (application fee)	S\$40/20
Renewal fee	S\$50-100

School-going children of any student holding a Student Pass may apply for enrolment in a government school.

PAYMENTS OF SCHOOL FEES

A bill stating the number of credits a student has registered for the quarter, the amount to pay and the dates for making payment will be placed in his/her mailbox during the second week of classes. A student can either pay in cash or by cheque to the Accounts Executive. Cheques should be made payable to “**East Asia School of Theology**”.

A late payment fee of S\$11.00 will be imposed if a student pays after the deadline. If a student is unable to pay on time, kindly consult the Accounts Executive before the deadline or a late fee will be imposed. Staff members of Campus Crusade for Christ (CCC) who wish to pay through deduction from their support account and those students who are on scholarship funding need not submit the bill to the Accounts Executive unless there are any errors.

Purchase of Textbooks

A copy of the book-list will be given to the students during registration time. Each student needs to submit his/her textbook order together with a non-refundable textbook deposit (S\$5 per book) to the Accountant. He/she can collect the textbooks when the books arrive. He/she can pay the balance by cash or cheque upon collection of the books.

FINANCIAL AID

The school seeks to provide financial assistance to needy students to help them complete their course of study at EAST. There are two kinds of aid available:

1. Tuition Assistance Plan (TAP)⁶

TAP is available to students who have tried but are unable to raise their full financial support for their studies. Campus Crusade staff members are eligible to apply for this aid if their support account is in deficit or they are unable to cover the full amount of the tuition fees. The money is not given directly to the students, but is used to settle the students' tuition fees. Please refer to the TAP application form for detailed terms and conditions.

2. Chest Fund (CHEST)⁷

CHEST helps students in need to defray the costs of the basic living expenses in Singapore. The amount given depends on availability of funds and the needs of the students. The money is normally given directly to the student on a monthly basis or as a one-time gift. Please refer to the CHEST application form for detailed terms and conditions.

Any student wishing to apply for any form of financial assistance must apply in writing by the first Friday of each academic year. He/she can collect the application form for financial aid from the **Students' Forms Tray** in the **Administrative Office**.

⁶ TAP is awarded according to the needs of the students and the amount of funds available.

⁷ CHEST is awarded according to the needs of the students and the amount of funds available.

Master's students who are receiving any financial aid must maintain a **GPA average of at least 2.7** in order to remain eligible for assistance. **Bachelor's students** must maintain a **GPA of at least 2.5** in order to remain eligible for assistance. Failure to do so will result in the loss of financial assistance.

Evaluation for financial assistance is done on a quarterly basis.

SCHOLARSHIP

1. Walter Steitz Memorial Scholarship

The Walter Steitz Memorial Scholarship has been set up in memory of the outstanding service and contribution of the late Dr. Walter Steitz to East Asia School of Theology. The award will be given to a current outstanding student who is doing the Master of Arts in Biblical Studies or Master of Divinity (Teaching & Exposition). The scholarship recipient will be chosen by the faculty of EAST. Academic achievement, leadership potential, and school involvement are the criteria by which the candidate is judged. Please refer to the information leaflet in the Administration Office for detailed terms and conditions.

2. Nam Foundation Scholarship

The Nam Foundation Ltd would give S\$10,000 annually towards the support of a student during his/her term of studies at EAST. The candidate must come from a developing country and have a call to be a missionary or pastor. He/she must maintain a cumulative GPA of at least 3.0 throughout his/her course of study at EAST. He/she must submit a progress report to the Nam Foundation Ltd twice a year. The Financial Aid Review Committee will make the selection at the beginning of the academic year, with recommendation from the faculty. The scholarship for that particular year will be given to the recipient at the beginning of the academic year.

3. Alumni Epaphroditus Aid (AEA)

The alumni of EAST have set up the Alumni Epaphroditus Aid (AEA) to render practical aid to full-time students who have contingency needs related to their internship or personal welfare. The amount given is dependent on availability of funds, the needs of the student and the stated terms and conditions of this aid.

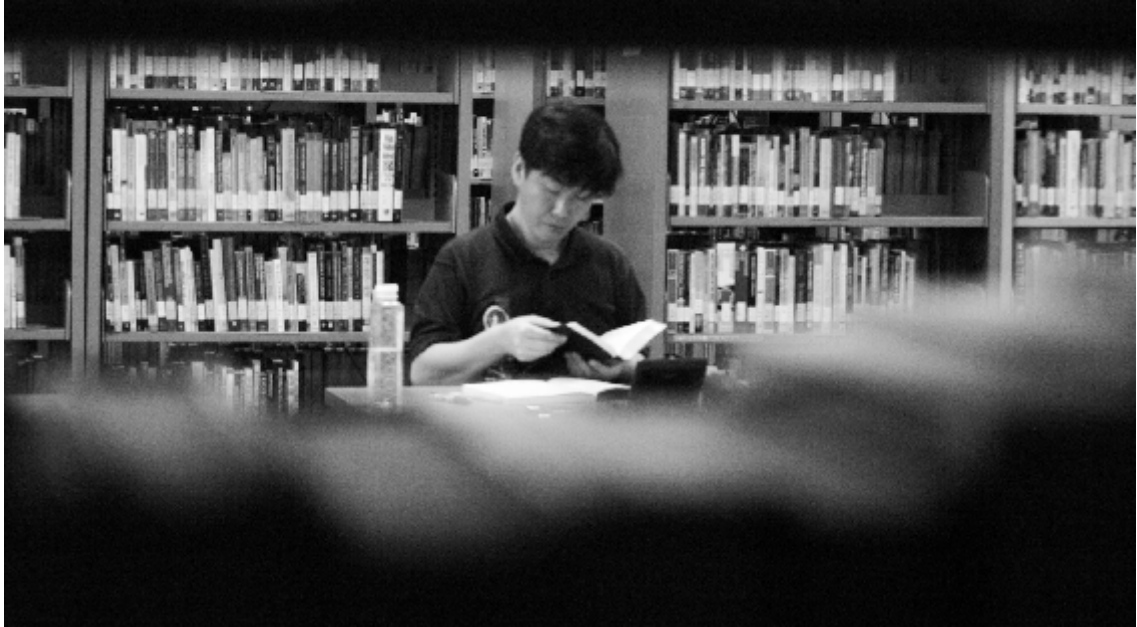

*Academic
Programmes*

INTRODUCTION

EAST offers an integrated EAST core curriculum for all programmes in line with our goal to train mission minded movement leaders for the world. The integrated core curriculum reflects three time elements: past, present and future. The past component connects the student to his/her past Christian heritage through classes on the Old and New Testaments, Church History and Systematic Theology. The present component allows the Christian to learn about the present world and self through anthropology and spiritual formation. Skill classes on preaching, teaching counselling and leading let students discover their gifts, calling and vocation. The curriculum is designed to be relevant to life and ministry, helping the student to develop both the heart and mind.

As they discover their gifts in the early part of their programmes, students can choose areas of emphasis in their programmes for their future study and development.

Academic Programmes

The school currently offers the following degree and certificate programmes:

1. The 143 credit-hour **Master of Divinity** (MDiv), with an emphasis in:
 - a. Teaching and Exposition
 - b. Intercultural Studies
 - c. General Studies
2. The 93 credit-hour **Master of Arts** (MA)
 - a. Master of Arts in Biblical Studies
 - b. Master of Arts in Intercultural Studies
 - c. Master of Arts in Pastoral Counselling (being reviewed)
3. The 127 credit-hour **Bachelor of Arts in Christian Ministry** (BA)
4. The 30 credit-hour **Graduate Certificate** with an emphasis in:
 - a. Pastoral Counselling
 - b. Biblical Studies
 - c. Intercultural Studies
 - d. Christian Ministry
5. The **Partners-in-Ministry** (PIM) **Certificate**

This is a non-degree certificate programme for spouses of students who are pursuing a degree programme with the school. The purpose of this programme is to ensure that both the husband and wife are given adequate preparation to meet the demands of Christian ministry together. The credits earned in this programme cannot be transferred to any degree programme. PIM students can enrol in all classes offered at EAST (except the Biblical language classes).

Master of Divinity Programme Requirements

	1 st Quarter		2 nd Quarter		3 rd Quarter	
		CR		CR		CR
1st Year	BLS 500 Biblical Interpretation	4	BLS 551 New Testament 1 – Gospels & Acts	4	BLS 552 New Testament 2 – Epistles & Revelation	4
	BLS 511 Greek 1	4	BLS 512 Greek 2	4	BLS 513 Greek Exegesis	4
	LMC 521 Advanced Evangelism & Discipleship	4	THS 500 Spiritual Transformation & Warfare	4	ICS 501 World Missions	4
	LMC 551 Effective Written Communication	2	LMC 552 Public Speaking & Preaching	2	LMC 501 Christian Leadership	2
			LMC 522 Church & Ministry Growth	2	LMC 571 Teaching	2
	Total	14	Total	16	Total	16
2nd Year 4	ICS 502 Intercultural Communication	2	BLS 521 Old Testament 1	4	BLS 522 Old Testament 2	4
	*Emphasis Class 1	4	*Emphasis Class 2	4	*Emphasis Class 3	4
	THS 501 Church History	4	THS 502 Theology 1	4	THS 503 Theology 2	4
	+Additional Core Class	4	Elective	2	Elective	2
	LMC 530 Field Practicum 1A	2	LMC 531 Field Practicum 1B	2	LMC 532 Field Practicum 1C	2
	Total	16	Total	16	Total	16
3rd Year	THS 504 Apologetics OR THS 551 Ethical Issues	4	+Additional Core Class	4	BLS Elective	4
	+Additional Core Class	4	*Emphasis Class	4	*Emphasis Class	4
	Elective	2	Elective	4	Elective	2
	BLS Elective	4	ICS 503 Religions of Asia	2	Elective	2
	LMC 533 Field Practicum 2A	2	LMC 534 Field Practicum 2B	2	LMC 535 Field Practicum 2C	2
	Total	16	Total	16	Total	14

+Choose any 12 credits from the Additional Core Classes listed below:

LMC 572 Christian Education	4	LMC 502 Christian Management OR LMC 503 Human Resource Development	2	
LMC 573 Advanced Teaching OR LMC 574 Teaching Practicum	4	LMC 553 Biblical Preaching	4	
PCM 510 Christian Marriage & Family OR PCM 502 Counselling	2			

Core Classes	:	82		Core classes:
Additional Core Classes+	:	12		
Emphasis Classes*	:	20		BLS = 40 credits
Electives	:	14		THS = 20 credits
Field Practicum	:	12		ICS = 8 credits
Cross Cultural Internship	:	3		LMC = 14 credits
Total	:	143		Total = 82 credits

* See Emphasis class list.

Note: Elective and emphasis classes are listed in suggested order • Cross Cultural Internship maybe completed during the vacation.

Emphasis classes for MDiv programmes (20 credits)

Teaching and Exposition

Emphasis Class 1	BLS 501 Hebrew 1	4
Emphasis Class 2	BLS 502 Hebrew 2	4
Emphasis Class 3	BLS 503 Hebrew Exegesis	4

Select 8 other credits from any BLS or THS or Christian Education classes or seminars.

Intercultural Studies

Emphasis Class 1	BLS 504 Using Hebrew Resources	4
------------------	--------------------------------	---

Other emphasis classes (select 16 other credits from any of the following subjects):

ICS 504 Cross Cultural Adjustment	4
ICS 505 Missionary Anthropology	4
ICS 506 Church Planting and Growth	2
ICS 507 Contextualization	4
ICS 508 Tent-making	4
ICS 509 Missionary Care	4
ICS 510 Urban Ministry	2
ICS 520-49 Intercultural Studies Seminars	2 or 4

General Studies

Emphasis Class 1	BLS 504 Using Hebrew Resources	4
------------------	--------------------------------	---

Other emphasis classes (select 16 other credits from any of the categories BLS, THS, LMC, ICS or PCM).

Distribution Requirements

The distribution of credit hours for the completion of the degree is as follows:

Core Classes	94
Emphasis Classes	20
Electives	14
Field Education	<u>15</u>
Total	143 credits

Graduation Requirements

1. Completion of the 143 credits as listed under distribution requirements with a minimum GPA of 2.5.
2. Completion of the cross-cultural internship.
3. File application for graduation with the Registrar at the beginning of the last year of the programme.
4. Approval of the candidate for the degree by an EAST faculty evaluation committee.
5. All tuition and fees paid in full.
6. Attendance at commencement exercises (unless special permission for absence is obtained).

MASTER OF ARTS IN BIBLICAL STUDIES

Description

The Master of Arts in Biblical Studies is a two-year (93 credits) graduate degree programme for bachelor's degree holders. It is designed to develop and equip students to be biblically grounded disciplers, able to teach in church and parachurch settings, especially in the Asian context.

Specific Objectives

1. To provide a working knowledge and understanding of the essential content of each book of the Bible including the key themes, issues and theological contributions.
2. To foster growth in Christian character and commitment to the Great Commission.
3. To equip the student with the foundational skills and methods needed for a lifelong study of the Word of God.
4. To develop and understanding of the essential doctrines of the Bible and God's working through the history of Christianity.
5. To develop skills for effective ministry in evangelism, discipleship, teaching, preaching and writing.

Admissions Requirements

The admissions requirements for MA programmes are the same as for MDiv programme.

Graduation Requirements

1. Completion of the 93 credits listed with a minimum GPA of 2.50.
2. Completion of the vocational internship.
3. File application for graduation with the Registrar at the beginning of the last year of the programme.
4. Approval of the candidate for the degree by an EAST faculty evaluation committee.
5. All tuition and fees paid in full.
6. Attendance at commencement exercises (unless special permission for absence is obtained).

Master of Arts in Biblical Studies Programme Requirements

	1st Quarter	CR	2nd Quarter	CR	3rd Quarter	CR																								
1st Year	BLS 500 Biblical Interpretation	4	BLS 551 New Testament 1 –Gospels to Acts	4	BLS 552 New Testament 2 – Epistles & Revelation	4																								
	LMC 521 Advanced Evangelism & Discipleship	4	THS 500 Spiritual Transformation & Warfare	4	ICS 501 World Missions	4																								
	Elective	4	Elective	4	*Emphasis Class	4																								
	LMC 551 Effective Written Communication	2	LMC 552 Public Speaking & Preaching	2	LMC 501 Christian Leadership	2																								
			LMC 522 Church & Ministry Growth	2	LMC 571 Teaching	2																								
	Total	14	Total	16	Total	16																								
2nd Year	*Emphasis Class	4	BLS 521 Old Testament 1	4	BLS 522 Old Testament 2	4																								
	THS 501 Church History	4	THS 502 Theology	4	THS 503 Theology 2	4																								
	*Emphasis Class	4	*Emphasis Class	4	*Emphasis Class	4																								
	*Emphasis Class	2																												
	LMC 530 Field Practicum 1A	2	LMC 531 Field Practicum 1B	2	LMC 532 Field Practicum 1C	2																								
	Total	16	Total	14	Total	14																								
*Choose any 22 credits from: BLS, Biblical Preaching, Advanced Teaching OR Teaching Practicum, Seminars on BLS/THS/CE																														
<table style="width: 100%; border-collapse: collapse;"> <tr> <td style="width: 30%;">Core Classes</td> <td style="width: 5%;">:</td> <td style="width: 10%; text-align: center;">54</td> <td style="width: 55%;">Core classes:</td> </tr> <tr> <td>Emphasis Classes*</td> <td>:</td> <td style="text-align: center;">22</td> <td>BLS = 20 credits</td> </tr> <tr> <td>Electives</td> <td>:</td> <td style="text-align: center;">8</td> <td>THS = 16 credits</td> </tr> <tr> <td>Field Practicum</td> <td>:</td> <td style="text-align: center;">6</td> <td>ICS = 4 credits</td> </tr> <tr> <td>Vocational Internship</td> <td>:</td> <td style="text-align: center;">3</td> <td>LMC =14 credits</td> </tr> <tr> <td>Total</td> <td>:</td> <td style="text-align: center;">93</td> <td></td> </tr> </table>							Core Classes	:	54	Core classes:	Emphasis Classes*	:	22	BLS = 20 credits	Electives	:	8	THS = 16 credits	Field Practicum	:	6	ICS = 4 credits	Vocational Internship	:	3	LMC =14 credits	Total	:	93	
Core Classes	:	54	Core classes:																											
Emphasis Classes*	:	22	BLS = 20 credits																											
Electives	:	8	THS = 16 credits																											
Field Practicum	:	6	ICS = 4 credits																											
Vocational Internship	:	3	LMC =14 credits																											
Total	:	93																												
Note: Elective and emphasis classes are listed in suggested order. Vocational Internship maybe completed during the vacation.																														

MASTER OF ARTS IN INTERCULTURAL STUDIES

Description

The Master of Arts in Intercultural Studies is a two-year (93 credits) graduate degree programme for bachelor's degree holders. It is designed for those who anticipate a ministry in a cross-cultural or multicultural setting urban setting, especially in the Asian context. It is suitable for missionaries, evangelists, missionary teachers and trainers, mission pastors, church planters, and leaders of mission organizations.

Specific Objectives

1. To foster growth in Christian character, cross-cultural adaptability, and commitment to our Lord's Great Commission.
2. To provide a working understanding of the essential content of each book of the Bible, and how the Bible enlightens mission conviction, strategy and practice.
3. To equip the student with the necessary working skills to study the Word of God and apply God's truth to life and ministry, especially in the Asian context.
4. To develop skills for effective intercultural living and ministry, communication of the gospel, discipleship, teaching, church planting and developing mission strategies.
5. To develop an understanding of the essential doctrines of the Bible and God's working through the history of Christianity.
6. To equip the student to analyze and understand the challenges and issues in missions and ministry, and to develop Christian perspectives concerning these challenges.

Admissions Requirements

The admissions requirements for MA programmes are the same as for MDiv programme.

Graduation Requirements

1. Completion of the 93 credits listed with a minimum GPA of 2.50.
2. Completion of the vocational internship.
3. File application for graduation with the Registrar at the beginning of the last year of the programme.
4. Approval of the candidate for the degree by an EAST faculty evaluation committee.
5. All tuition and fees paid in full.
6. Attendance at commencement exercises (unless special permission is obtained).

Master of Arts in Intercultural Studies Programme Requirements

	1st Quarter	CR	2nd Quarter	CR	3rd Quarter	CR												
1st Year	BLS 500 Biblical Interpretation	4	BLS 551 New Testament 1 – Gospels to Acts	4	BLS 552 New Testament 2 – Epistles & Revelation	4												
	LMC 521 Advanced Evangelism & Discipleship	4	THS 500 Spiritual Transformation & Warfare	4	ICS 501 World Missions	4												
	*ICS 502 Intercultural Communication	2	Elective	4	*Emphasis Class	4												
	LMC 551 Effective Written Communication	2	LMC 552 Public Speaking & Preaching	2	LMC 501 Christian Leadership	2												
	Elective	2	LMC 522 Church & Ministry Growth	2	LMC 571 Teaching	2												
	Total	14	Total	16	Total	16												
2nd Year	*Emphasis Class	4	BLS 521 Old Testament 1	4	BLS 522 Old Testament 2	4												
	*Emphasis Class	4	*Emphasis Class	2	*Emphasis Class	2												
	Elective	2	*ICS 503 Religions of Asia	2	*Emphasis Class	4												
	THS 501 Church History	4	THS 502 Theology 1	4	THS 503 Theology 2	4												
	LMC 530 Field Practicum 1A	2	LMC 531 Field Practicum 1B	2	LMC 532 Field Practicum 1C	2												
	Total	16	Total	14	Total	14												
<p>*Emphasis Classes: Choose any 18 credits from this list:</p> <table style="width: 100%; border: none;"> <tr> <td style="width: 50%;">ICS 504 Cross-Cultural Adjustment (4cr)</td> <td style="width: 50%;">ICS 507 Contextualization (4cr)</td> </tr> <tr> <td>ICS 505 Missionary Anthropology (4cr)</td> <td>ICS 509 Missionary Care (4cr)</td> </tr> <tr> <td>ICS 508 Tent-making (4cr)</td> <td>ICS 510 Urban Ministry (2cr)</td> </tr> <tr> <td>ICS 506 Church Planting & Growth (4cr)</td> <td>ICS 520-49 Intercultural Studies Seminar (2 or 4cr)</td> </tr> </table>							ICS 504 Cross-Cultural Adjustment (4cr)	ICS 507 Contextualization (4cr)	ICS 505 Missionary Anthropology (4cr)	ICS 509 Missionary Care (4cr)	ICS 508 Tent-making (4cr)	ICS 510 Urban Ministry (2cr)	ICS 506 Church Planting & Growth (4cr)	ICS 520-49 Intercultural Studies Seminar (2 or 4cr)				
ICS 504 Cross-Cultural Adjustment (4cr)	ICS 507 Contextualization (4cr)																	
ICS 505 Missionary Anthropology (4cr)	ICS 509 Missionary Care (4cr)																	
ICS 508 Tent-making (4cr)	ICS 510 Urban Ministry (2cr)																	
ICS 506 Church Planting & Growth (4cr)	ICS 520-49 Intercultural Studies Seminar (2 or 4cr)																	
<table style="width: 100%; border: none;"> <tr> <td style="width: 50%;">Core Classes : 54</td> <td style="width: 50%;">Core classes:</td> </tr> <tr> <td>Emphasis Classes* : 22</td> <td>BLS = 20 credits</td> </tr> <tr> <td>Electives : 8</td> <td>THS = 16 credits</td> </tr> <tr> <td>Field Practicum : 6</td> <td>ICS = 4 credits</td> </tr> <tr> <td>Vocational Internship : 3</td> <td>LMC = 14 credits</td> </tr> <tr> <td>Total : 93</td> <td></td> </tr> </table> <p>Note: Elective and emphasis classes are listed in suggested order. Vocational Internship maybe completed during the vacation.</p>							Core Classes : 54	Core classes:	Emphasis Classes* : 22	BLS = 20 credits	Electives : 8	THS = 16 credits	Field Practicum : 6	ICS = 4 credits	Vocational Internship : 3	LMC = 14 credits	Total : 93	
Core Classes : 54	Core classes:																	
Emphasis Classes* : 22	BLS = 20 credits																	
Electives : 8	THS = 16 credits																	
Field Practicum : 6	ICS = 4 credits																	
Vocational Internship : 3	LMC = 14 credits																	
Total : 93																		

GRADUATE CERTIFICATE

Description

The Graduate Certificate is a 30 credit graduate level programme for bachelor's degree holders. It is designed for church members, lay leaders, and Christian workers who want to develop and equip themselves for more effective Christian service. This programme exposes a student to classes in Bible, Theology, Counselling, Missions, Ministry, and Communication. The credits earned can be applied to a master's degree programme.

The student may choose to complete the more general *Graduate Certificate in Christian Ministry* for a broad exposure to a wide range of classes. Or he/she may choose a more focused certificate in one of the following emphases:

Graduate Certificate in Biblical Studies
Graduate Certificate in Intercultural Studies
Graduate Certificate in Pastoral Counselling

Programme Explanation

The student in the Graduate Certificate programme chooses one or two classes from each of the category:

Biblical Studies	- 4 credits
Theological and Historical Studies	- 4 credits
Leadership, Ministry, and Communication	- 4 credits
Intercultural Studies	- 4 credits

In addition to these 16 credits, the student selects 14 more elective credits. The elective credits can be chosen from a variety of class categories for the broader *Graduate Certificate in Christian Ministry*. Those who wish to focus on a special area may choose all or most of their elective credits in one of the three special emphases: *Pastoral Counselling, Biblical Studies, or Intercultural Studies*. For a Graduate Certificate in a special area of emphasis, at least 12 of the 30 credits would need to be in the chosen area of emphasis.

Admissions Requirements

EAST considers each applicant's qualifications in these five areas:

1. Maturity (personal, social, and spiritual)
2. Ministry experience
3. Leadership ability
4. Academic ability
5. Academic entry requirement:
A bachelor's degree from an accredited or recognized university or college

Note: EAST reserves the right to make exceptions to the above policy.

Graduate Certificate in Christian Ministry

Category	All Classes = 4 Credits except * = 2 Credits			Minimum Credits from each Category
Biblical Studies	Biblical Interpretation	Old Testament 1	New Testament 1	4
	Other BS Elective Classes	Old Testament 2	New Testament 2	
Theological & Historical Studies	Spiritual Transformation & Warfare	Church History	Theology 1 or 2	4
	Other THS Elective Classes			
Leadership, Ministry & Communication	Public Speaking & Preaching *	Christian Leadership *	Advanced Evangelism & Discipleship	4
	Church & Ministry Growth *	Teaching *	Effective Writing *	
	Other LMC Elective Classes	Christian Management *	Urban Ministry*	
Inter-Cultural Studies	World Missions	Religions of Asia*	Intercultural Communication*	4
	Other ICS Elective Classes	Missionary Care*		
Total				16 Credits
<p>14 Elective Credits</p> <p>Select any 14 credits from the classes listed in this programme or other classes offered at EAST</p> <p>Total: 30 Credits</p>				

Graduate Certificate in Biblical Studies

Biblical Studies Emphasis

Select 12 credits from the following classes:

Biblical Interpretation	Old Testament 1
Old Testament 2	New Testament 1
New Testament 2	Other Bible Elective classes

Category	All Classes = 4 Credits except * = 2 Credits			Minimum Credits from each Category
Theological & Historical Studies	Spiritual Transformation & Warfare	Theology 1 or 2	Church History	4
	Other THS Elective Classes			
Leadership, Ministry & Communication	Public Speaking & Preaching *	Christian Leadership *	Advanced Evangelism & Discipleship	4
	Church & Ministry Growth *	Teaching *	Effective Writing *	
	Other LMC Elective Classes	Christian Management *	Urban Ministry *	
Inter-Cultural Studies	World Missions	Religions of Asia *	Intercultural Communication *	4
	Other ICS Elective Classes	Missionary Care *		
Total				12 Credits
<p>6 Credits - Electives</p> <p>Select any 6 credits from the classes listed in this programme or other classes offered at EAST</p> <p>Total: 30 Credits</p>				

Graduate Certificate in Inter-Cultural Studies

Inter-Cultural Studies Emphasis

Select 12 credits from the following classes:

World Missions

Intercultural Communication *

Missionary Anthropology

Tentmaking *

Religions of Asia *

Cross-cultural Adjustment

Missionary Care

Other ICS Electives

Category	All Classes = 4 Credits except * = 2 Credits			Minimum Credits from each Category
Biblical Studies	Biblical Interpretation	Old Testament 1	New Testament 1	4
	Other BS Elective Classes	Old Testament 2	New Testament 2	
Theological & Historical Studies	Spiritual Transformation & Warfare	Theology 1 or 2	Church History	4
	Other THS Elective Classes			
Leadership, Ministry & Communication	Public Speaking & Preaching *	Christian Leadership *	Advanced Evangelism & Discipleship	4
	Church & Ministry Growth*	Teaching *	Effective Writing*	
	Other LMC Elective Classes	Christian Management *	Urban Ministry*	
Total				12 Credits
<p>6 Credits - Electives</p> <p>Select any 6 credits from the classes listed in this programme or other classes offered at EAST.</p> <p>Total: 30 Credits</p>				

Graduate Certificate in Pastoral Counselling

12 Credits in Pastoral Counselling

Select 12 credits from the following classes:

Counselling Methods and Techniques

Counselling Theory *

Group Counselling *

Pre-marital and Marriage Counselling

Character Development *

Crisis Counselling *

Personal Assessment *

Christian Marriage and Family *

Family Counselling *

Category	All Classes = 4 Credits except * = 2 Credits			Minimum Credits from each Category
Biblical Studies	Biblical Interpretation	Old Testament 1	New Testament 1	4
	Other BS Elective Classes	Old Testament 2	New Testament 2	
Theological & Historical Studies	Spiritual Transformation & Warfare	Church History	Theology 1 or 2	4
	Other THS Elective Classes			
Leadership, Ministry & Communication	Public Speaking & Preaching *	Christian Leadership *	Advanced Evangelism & Discipleship	4
	Church & Ministry Growth *	Teaching *	Effective Writing*	
	Other LMC Elective Classes	Christian Management *	Urban Ministry *	
Inter-Cultural Studies	World Missions	Religions of Asia*	Intercultural Communication*	4
	Other ICS Elective Classes	Missionary Care*		
Total				16 Credits
2 Elective Credits	Select any 2 credits from the classes listed in this programme or other classes offered at EAST.			
Total: 30 Credits				

BACHELOR OF ARTS IN CHRISTIAN MINISTRY

Description

The Bachelor of Arts in Christian Ministry is a special 127-credit degree programme. The programme provides a broad foundation for those who anticipate continued vocational Christian service and wish to continue their theological education at the master's level. It is designed for those who have completed a diploma from a recognized tertiary institution (such as a Polytechnic), have at least two years of field ministry experience and plan to continue in full-time Christian Ministry

The Bachelor of Arts in Christian Ministry students may earn up to 40 credits of advanced standing by satisfying the objectives of 10 out of 13 possible Bachelor Foundational subjects. Advanced standing credits may also be acquired by transfer credits. Those students who acquire 40 credits of advanced standing can complete the Bachelor of Arts in Christian Ministry programme in two years. Those with less than 40 credits of advanced standing are required to take more classes at EAST.

Specific Objectives

1. To foster the student's growth in Christian character and commitment to our Lord's Great Commission.
2. To provide the student with a basic knowledge and understanding of the basic content of the Bible and the basic skills and methods needed to study the Word of God.
3. To develop skills for effective ministry in evangelism, discipleship, teaching, writing, and teaching people to follow God's Word.
4. To examine the essential doctrines of Christianity of God's working through the history of Christianity.

Admissions Requirements

EAST considers each applicant's qualifications in these five areas:

1. Maturity (personal, social, and spiritual)
2. Ministry experience – at least two years of filed ministry experience with plans to continue in full-time Christian Ministry.
3. Leadership ability
4. Academic ability
5. Academic entry requirement:
An A-level certificate or diploma from a recognized tertiary institution

Note: EAST reserves the right to make exceptions to the above policy.

Graduation Requirements

1. Completion of the 127 credits listed with a minimum GPA of 2.25.
2. Completion of the cross-cultural internship.
3. Completion of any deficiencies require by the programme.
4. File application for graduation with the Registrar at the beginning of the last year of the programme.
5. Approval of the candidate for the degree by an EAST faculty evaluation committee.
6. All tuition and fees paid in full.
7. Attendance at commencement exercises (unless special permission for absence is obtained).

Bachelor of Arts in Christian Ministry Programme Requirements

Select any 10 Foundational Subjects from this list below						
Foundational Subjects	BLS 401 Biblical Foundations	4	THS 401 Doctrine Survey	4	THS 403 Prayer & Christian Disciplines	4
	THS 402 Spiritual Life & Growth	4	LMC 402 Discipleship	4	ICS 401 Cross-cultural Ministry	4
	LMC 401 Evangelism	4	LMC 404 Personal Development	4	LMC 403 Leading & Teaching Groups	4
	LMC 405 Christian Service	4	LMC 406 Specialized Ministries	4	LMC 408 Ministry Development & Leadership	4
					LMC 407 Fund Raising	4
1st Year	1st Quarter	CR	2nd Quarter	CR	3rd Quarter	CR
	BLS 500 Biblical Interpretation	4	BLS 551 New Testament 1	4	BLS 552 New Testament 2	4
	LMC 521 Advanced Evangelism & Discipleship	4	THS 500 Spiritual Transformation & Warfare	4	ICS 501 World Mission	4
	*Character Development OR Critical Thinking	2	*LMC 452 Effective Reading	2	LMC 501 Christian Leadership	2
	LMC 551 Effective Written Communication	2	LMC 552 Public Speaking & Preaching	2	LMC 571 Teaching	2
	Elective	2	LMC 522 Church & Ministry Growth	2	Elective	2
	Total	14	Total	14	Total	14
	Total	14	Total	14	Total	14
2nd Year	*PCM 510 Christian Marriage & Family	2	BLS 521 Old Testament 1	4	BLS 522 Old Testament 2	4
	THS 501 Church History	4	THS 502 Theology 1	4	THS 503 Theology 2	4
	*Emphasis Class	2	*Emphasis Class	2	*Emphasis Class	2
	Elective	4	Elective	2	Elective	2
	LCM 530 Field Practicum 1A	2	LCM 531 Field Practicum 1B	2	LCM 532 Field Practicum 1C	2
	Total	14	Total	14	Total	14
*Emphasis Classes						
Choose 6 credits from the emphasis' list below:						
Basic Pastoral Counselling	2	LMC 502 Christian Management	2	PCM 501 Personal Assessment	2	
Intercultural Comm.	2	ICS 503 Religions of Asia	2			
Christian Education	4					
Foundational Credits	: 40	Core Classes:				
Core Classes	: 54	BLS = 20 credits				
Emphasis Classes*	: 12	THS = 16 credits				
Electives	: 12	ICS = 4 credits				
Field Practicum	: 6	LMC = 14 credits				
Cross Cultural Internship	: 3					
Total	: 127					
Note: Elective and emphasis classes are listed in suggested order • Cross Cultural Internship may be completed during the vacation.						





*CLASS
DESCRIPTION*

CLASS DESCRIPTION KEY

Class Code

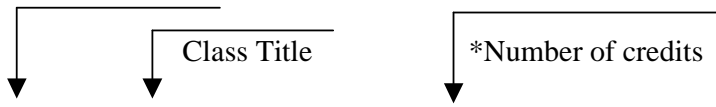

BLS503 Hebrew Exegesis (4 Credits)

→ A study of the basic methods and principles in the exegesis of the Old Testament, including word studies, textual criticism and syntax. These exegetical methods and principles will be applied to selected Old Testament texts.

Prerequisite: BLS501 & 502 Hebrew 1 & 2

Class Description

Prerequisites Required to Take Class

***All classes are offered as 4 credits, unless otherwise stated.**

CLASS NUMBERING SYSTEM

The following alpha-numeric system of class numbering is used:

The first three letters indicate the category of studies.

BLS: Biblical & Language Studies

THS: Theological & Historical Studies

ICS: Inter-Cultural Studies

LMC: Leadership, Ministry, & Communication

PCM: Pastoral Counselling

The first numeric digit which follows the letters indicates the class level:

4: Classes in the Bachelor level

5: Classes in the Master level

The last two numeric digits refer to class sequence.

Example: BLS503 Hebrew Exegesis

The first three letters “BLS” indicates that this class is in Biblical & Language Studies category. The first numeric digit “5” indicates that this is a Master level class. The last two numeric digits “03” indicates the sequence within class categories or sub-categories.

The following are the classes offered at EAST (unless stipulated otherwise, all classes are worth 4 quarter credits):

BIBLICAL & LANGUAGE STUDIES (BLS)

401 Biblical Foundations

Focuses on a foundational knowledge and understanding of the Bible including: composition and authorship of the Bible; structure of the Bible; relationship of Old Testament & New Testament; authority and reliability of the Bible; centrality of Christ in the Bible; and importance of the Bible in Christian living and ministry.

500 Biblical Interpretation

An introduction to the principles of biblical interpretation. Emphasis will be given to learning how to read, interpret, and apply the various genres of the Bible to our lives.
Prerequisite: English Grammar Review Seminar

Hebrew Studies

501 Hebrew 1

An introduction to the elements of Hebrew grammar, including morphology, basic declensions, conjugations, and syntax. Attention is also given to vocabulary building, translation, and grammatical diagramming.

502 Hebrew 2

A continuation of the study of the elements of Hebrew grammar, including morphology, basic declensions, conjugations, and syntax. Attention is given to vocabulary building, translation, and grammatical diagramming.
Prerequisite: BLS501 Hebrew 1.

503 Hebrew Exegesis

A study of the basic methods and principles in the exegesis of the Old Testament, including word studies, textual criticism and syntax. These exegetical methods and principles will be applied to selected Old Testament texts.
Prerequisite: BLS501 & 502 Hebrew 1 & 2.

504 Using Hebrew Resources

An overview of biblical Hebrew grammar and syntax, and an introduction to selected language tools (including computer aids) in understanding Hebrew. The student will learn how to use these resources as aids to biblical studies, and be introduced to a method of doing word studies. This class is not for students who are taking Hebrew I, II, and Hebrew Exegesis.
Prerequisites: BLS500 Biblical Interpretation

Greek Studies

511 Greek 1

An introduction to the elements of Greek grammar, including morphology, basic declensions, conjugations, and syntax. Attention is also given to vocabulary building, translation, and grammatical diagramming.

Prerequisite: English Grammar Review Seminar

512 Greek 2

A continuation of the study of the elements of Greek grammar, including morphology, basic declensions, conjugations, and syntax. Attention is given to vocabulary building, translation, and grammatical diagramming. *Prerequisite: BLS511 Greek 1*

513 Greek Exegesis

A study of the basic methods and principles in the exegesis of the New Testament, including word studies, textual criticism and syntax. These exegetical methods and principles will be applied to selected New Testament texts.

Prerequisite: BLS511 & 512 Greek 1 & 2

Old Testament Studies

521 Old Testament 1: Genesis-Esther

A study of the formation and background of the Old Testament, and the covenant narrative from Genesis through Esther. Attention is given to various critical issues of their backgrounds, theological themes, and relevance to Christians today.

522 Old Testament 2: Job-Malachi

A study of the prophetic books and poetic writings of the Old Testament. Attention is given to the various critical issues of their backgrounds, theological themes, and their relevance to Christians today.

530-49 Old Testament Seminars

Scholars bring special expertise in an area of Old Testament studies to enrich the usual classes.

New Testament Studies

551 New Testament 1: Gospels & Acts

A study of the formation and background of the New Testament, the four gospels and Acts in the light of their historical and literary contexts. Attention is given to various critical issues of their backgrounds, theological themes, and their relevance to Christians today.

552 New Testament 2: Epistles & Revelation

A study of the New Testament epistles and Revelation in the light of their socio-historical context. Attention is given to the various critical issues of their backgrounds, theological themes, and their relevance to Christians today.

Synoptic Studies

556 Matthew / 557 Mark / 558 Luke-Acts

A close reading of a selected gospel. Emphasis is given to the structure, theology and major themes of the selected gospel and its theological significance today.

Pauline Studies

561 Romans / 562 Corinthians / 563 Pastoral Epistles

A study of selected Pauline epistle(s) in the light of its socio-historical context. Emphasis is given to the major theological issues in the epistle(s) and their relevance to the present-day church.

Johannine Studies

571 John / 572 Johannine Epistles / 573 Revelation

A study of selected Johannine writing(s) in the light of its socio-historical context. Emphasis will be given to its theological significance for the church today.

General Studies

583 Hebrews / 584 James

A study of the General Epistle(s). Emphasis is given to its contemporary significance to the church.

THEOLOGICAL & HISTORICAL STUDIES (THS)

401 Doctrine Survey

Focuses on biblical knowledge, understanding, and conviction concerning the major doctrines of the Christian faith, including the doctrines of: God, person and work of Jesus Christ, the Holy Spirit, the Bible, man and sin, salvation, the church, death and resurrection, and future things.

402 Spiritual Life and Growth

Focuses principles of spiritual growth and a vital spiritual life. Includes such things as: assurance of salvation, growing in the Christian life, being filled and walking in the Holy Spirit, our relationship and communion with God, discerning God's leading in our life, and fellowship with other believers. Application: understanding and applying these principles in one's life.

403 Prayer and Christian Disciplines

Focuses on biblical principles, practical methods and the practice of prayer, and Christian disciplines. Includes such things as: regular quiet time with God; personal prayer life; small group and corporate prayer; reading, studying, meditating, and applying Scripture; stewardship of time, talent, and treasure; worship and confession; exercising disciplines such as solitude, fasting, submission, simplicity, and service.

500 Spiritual Transformation and Warfare

This class examines God's plan to bring man into an eternal life changing relationship with God. It shows how God's great salvation is worked out in our Christian life to transform us to be more like Christ. It provides biblical and practical instruction concerning the believer's involvement in spiritual warfare, the battle for the mind, and how to resist and overcome demonic influence. Students learn a biblical worldview of the unseen spirit world, the position and authority they have in Christ, and how to help people having spiritual conflicts find freedom in Christ.

501 Church History

An overview and interpretative study of Church History from the early church to the present. Emphasis will be given to the major movements that influenced the development of the church and ways that the church made an impact on the world. Attention is also given to the individuals and issues behind various movements and revivals, and the lessons for Christians today.

502 Theology 1: God, Man, & Christ

A systematic study of God & creation, revelation & the Bible, man & sin, and the person & work of Christ. Related contemporary issues will be evaluated in order to arrive at a sound, evangelical understanding of the subject matter.

503 Theology 2: The Spirit, Church & Last Things

A systematic study of the Holy Spirit, the Church, and the last things. Related contemporary issues will be evaluated in order to arrive at a sound, evangelical understanding of the subject matter.

504 Christian Apologetics and Worldviews

This course considers what worldviews are and their significance to the individuals and society that hold them and evaluate them. Religious and non-religious options will be introduced, including existentialism, New Age, postmodernism, animism, Buddhism, and Islam.

505 New Testament Theology

An examination of the major theological themes of the New Testament in light of their historical-cultural contexts. Attention is given to the history, methodology, and presuppositions of the discipline.

506 Old Testament Theology

An examination of the theological framework of the Old Testament. Special attention is given to understanding the kingdom of God in the Old Testament and how to "seek first God's kingdom and His righteousness" in contemporary society.

530-49 Theology/History Seminars

Scholars bring special expertise in an area of Theological or Historical studies to enrich the usual classes.

551 Ethical Issues in Asia

A study of the basic ethical principles derived from Scriptures to resolve various critical issues confronting Christians ministering in Asia today.

INTER-CULTURAL STUDIES (ICS)

401 Cross-cultural Ministry

Focus on serving in a cross-cultural ministry and developing a ministry with people of a different culture. Includes such things as: ministry concentration with people of another culture, serving in a ministry in another country, sharing the gospel with people of another cultural background, discipling people of different cultural background, involvement with a church or churches of a different culture, and reading concerning cross-cultural ministry and missions.

501 World Mission

An introduction to the biblical, historical, cultural, and strategic perspectives of world mission. Special emphasis is given to the historical development of the expansion of Christianity and the people and missionary methods employed and lessons for today. Major issues in the mission movement and what God is doing around the world today are examined. Students develop a plan to increase their involvement in mission.

502 Intercultural Communication (2cr)

A study of the basic principles of communication and the key issues in intercultural communication. Students will experience the complexity of communicating the gospel cross-culturally through experiential learning activities in class. They will acquire tools for studying the host culture and how to communicate in a culturally relevant way and become fruitful workers in other cultures.

503 Religions of Asia (2cr)

A study of the beliefs and practices of the adherents of the major non-Christian religions of Asia as well as New Age beliefs and practices. Gives suggestions concerning sharing the claims of Christ with those from each of the various non-Christian religions examined.

504 Cross-cultural Adjustment

Employs game theory, case studies, and active student participation to impart essential concepts and skills for cross-cultural living and effective ministry focusing on personal and interpersonal adjustment, and relationships.

505 Missionary Anthropology

A study of the dynamics of culture and their effects on people and mission. Students will be guided through topics such as culture and worldview, cultural systems, cultural identities of missionaries, and anthropological methodologies that are helpful in mission fields.

Prerequisite: MIS 502 Intercultural Communication.

506 Church Planting and Growth (2 cr)

A study of effective principles of cross-cultural church planting. Emphasis is given to developing a master plan for planting a new church or ministry. Includes biblical foundation, analysis of target group, roles & responsibilities of planters, teamwork, developing leaders, monitoring growth & implementing growth principles.

Prerequisite: LMC 522 Church and Ministry Growth

507 Contextualization

This class surveys trends in the contextualization of theology and ministry, identifying themes and methods appropriate for evangelicals in Asia. It also examines and evaluates some case studies of contextualization. Students will identify context related issues in order to develop effective strategies to communicate the gospel of Christ cross culturally and establish a cross-cultural ministry or church.

Prerequisite: LMC 502 Intercultural Communication.

508 Tentmaking

This class presents the tentmaking strategy (bi-vocational missions) as an essential means to help fulfil the Great Commission in creative access nations. Students study the biblical basis for tentmaking, evaluate their personal readiness, and develop a personal plan to prepare themselves for successful ministry in a host culture.

509 Missionary Care

This class investigates some of the biblical basis for the development of missionary care. It explores and evaluates strategies to help build the resilience and effectiveness of the missionaries, and to provide appropriate support and care of missionaries and their children.

510 Urban Ministry (2cr)

This class examines the biblical understanding of cities, the phenomenal growth of cities through the centuries, and issues in urbanization. It also deals with the analysis of urban people groups and their needs, and how we can develop practical principles and strategies to evangelize and minister to these city dwellers, especially in Asia.

520-49 Inter-Cultural Studies Seminars

Scholars bring special expertise in an area of Inter-Cultural studies.

LEADERSHIP, MINISTRY, AND COMMUNICATION (LMC)**401 Evangelism**

Focuses on principles, methods, and experience in sharing the gospel with others personally & in groups. Includes: making evangelistic contacts, communicating the gospel clearly, bringing people to a decision in personal & group evangelism settings, communicating assurance of salvation, motivating new believers to become involved with other Christians, planning & setting up evangelistic meetings, preparing and giving a personal testimony and evangelistic messages, determining the response from the group, following through with those who respond positively, and use of evangelistic materials. Application: involvement in personal evangelism and participation in evangelistic group meetings.

402 Discipleship

Focuses on principles, methods, and experience in establishing new believers in the faith and helping them progressively follow Christ more closely. Includes such things as: establishing relationships with and following up new believers; helping new or immature Christian understand and live out their identity in Christ, and the ministry of the Holy Spirit; helping new or immature Christians establish a practice of prayer, study of God's Word, and involvement in a local church; using small groups to

nurture and build disciples; using spiritual multiplication to build Christian movements; motivating believers to participate in Christian conferences, church camps, retreats, seminars, etc. for growth and vision; training others to evangelize and disciple others.

403 Leading and Teaching Groups

Focuses on the principles and experience of leading and teaching groups such as small group Bible studies, cell groups, Sunday School classes, prayer groups, discipleship groups, and nurture groups. Not limited to small groups. Includes such things as: establishing groups, building relationship with group members, group dynamics, planning and conducting group meetings, personally ministering to the people in the group, preparing lessons and leading guided discussions, choosing appropriate content or materials for the group, formulating objectives for the group and teaching and leading in light of these objectives, and using various methods to teach or lead groups.

404 Personal Development

Focuses on planning for personal development and ministry, and implementing those plans. Includes such things as: identifying one's gifts, abilities, strengths and weakness; formulating plans and objectives for personal development; evaluating one's development and ministry; developing and implementing personal ministry plans and strategies; personal time management; determining God's leading and direction in one's life and ministry.

405 Christian Service

May include a wide range of experience in Christian service in the church, community, mission, or parachurch settings such as service on a church committee, helping behind the scenes with a ministry, leading singing, emceeding a meeting and introducing others, analyzing an audience, preparing and giving messages or sermons, giving counsel or comfort, serving on a short term mission team, etc.

406 Specialized Ministries

Focuses on applying principles of evangelism, discipleship, and ministry to particular target groups of people such as children, youth, tertiary students, young adults, etc., or a special type of ministry such as music ministry, etc. Includes such things as: identifying characteristics of a target group; the principles, methods, and strategies that have been effective in ministering to a target group; utilizing a specialized ministry with various groups. Application involves participation with a particular target group or with a specialized ministry over an extended period of time.

407 Fund Raising

Focuses on principles and procedures of raising funds for Christian causes or ministries including the biblical basis of raising funds, the integration of faith and action in fund raising, the relationship between raising funds and ministering to and communicating with those who give. Application: raising and maintaining one's financial support and/or raising funds in the church, or for Christian causes or ministries.

408 Ministry Development and Leadership

Focuses on developing a ministry. Includes such things as: formulating ministry plans and objectives with God's guidance; implementing plans by helping to lead, organize, delegate, and manage a ministry; evaluating a ministry and making adjustments;

identifying and utilizing the strengths of others for effective ministry; training and equipping others in ministry; leadership training and experience.

442 English for Seminarians 1 (12 cr)

This class will develop the English ability of students for whom English is a second language. Significant attention is given to grammar, reading, speaking and writing within the context of Christian themes and topics. Credits earned for this class are not applied toward the credits required for a master's degree.

443 English for Seminarians 2 (12 cr)

This is a continuation class for English for Seminarians 1. Credits earned for this class are not applied toward the credits required for a master's degree.

445 English Coaching for Seminarians (2 cr)

This is a personalized one-on-one coaching for students who need help with their English while undertaking course work at EAST. Students meet with their respective coaches for approximately 2 hours a week. Credits earned for this class are not applied toward the credits required for a master's degree.

447 English Coaching for Seminarians (4 cr)

This is an extended personalized one-on-one coaching for students who need help with their English while undertaking course work at EAST. Students meet with their respective coaches for approximately 4 hours a week. Credits earned for this class are not applied toward the credits required for a master's degree.

452 Effective Reading (2 cr)

Helps the students acquire important basic skills for effective analysis of written material. The students apply these skills in their reading, research and preparation of written papers, and oral presentations.

453 Creative and Critical Thinking (2 cr)

Designed to help develop creative and critical thinking of the students. Activities and projects are geared to stimulate the students towards applying creative and critical thinking in their ministries and areas of interests.

Leadership

501 Christian Leadership (2 cr)

An exploration of the ministry of leadership in Christian faith communities. Emphasis is given to the development of a biblical understanding of Christian leadership and the discovery of oneself in the developmental process of a leader.

502 Christian Management (2 cr)

A study of the development and management of Christian learning organizations. Emphasis is given to the seven disciplines of spiritual vitality, relational vitality, personal mastery, systems thinking, mental models, shared vision, and team learning that are necessary for dynamic Christian learning organizations.

503 Human Resource Development (2 cr)

A study of the development and management of human resources. Attention is given to how both people's needs and organizational needs can be met through

appropriate recruitment, selection, placement, organization, development, training, career planning, and care of personnel.

510-19 Leadership Seminars

Scholars bring special expertise in an area of leadership to enrich the usual classes.

Ministry

521 Advanced Evangelism and Discipleship

An examination of the biblical understanding of evangelism and discipleship in contrast to some current views and practices. Emphasis is given to the development of practical ideas and strategy for evangelistic and discipleship ministries.

522 Church and Ministry Growth (2 cr)

This study focuses on fifteen multi-dimensional growth principles that apply to any church or Christian ministry. Each principle is examined and applied. In light of these principles, students will do growth-focused diagnosis of their ministry and church.

530-32 Field Practicum 1A/ 1B/ 1C (2 cr each)

The field education programme allows the students to practice what they learn in the classroom in the context of an ongoing ministry. It promotes integration of academic studies, ministry, and life. Field practicum is not just about doing ministry but also learning in ministry. The student develops and implements a yearly plan in consultation with a faculty supervisor.

533-35 Field Practicum 2A/ 2B/ 2C (2 cr each)

A continuation of Field Practicum 1.

536-38 Field Practicum 3A/ 3B/ 3C (2 cr each)

A continuation of Field Practicum 2 for students in BA-MDiv programme

539 Cross-Cultural Internship (3 cr)

The student spends at least four weeks in a cross-cultural and/or multicultural setting, focusing primarily on evangelism and discipleship-related ministry. The student has the opportunity to live and minister in a cross-cultural context and to integrate knowledge with today's challenges in missions. This exposure will help students develop a personal vision for the world and cross-cultural ministry.

540 Vocational Internship (3 cr)

The internship allows students maximum exposure and opportunities for hands-on ministry in their chosen area of emphasis or interest to help prepare them for their future ministry. The students spend at least four weeks working under the supervision of a qualified mentor. The internship can be done overseas or locally.

545-49 Ministry Seminars

Scholars bring special expertise in an area of ministry to enrich the usual classes.

Communication

551 Effective Written Communication (2 cr)

Examines the principles of effective written communication including background research, arrangement of material, good style, and proper use of words. The student also learns the basic mechanics and standards for the writing of term papers and reports.

552 Public Speaking & Preaching (2 cr)

An exploration of the students' readiness for the ministry of speaking and preaching. The students will explore the different stages of the communication process and some of the vital factors to effectively communicate their message to different audiences. The students will also learn to plan, prepare, and deliver messages.

553 Biblical Preaching

A study on the methodology and practice of biblical preaching. Emphasis is given to the planning, writing, and delivery of expository sermons from different genres with accuracy, clarity, sensitivity, and relevancy. Students will deliver sermons and receive evaluation from fellow students and the instructor.

Prerequisites: BLS500 Biblical Interpretation; LMC552 Public Speaking & Preaching

560-69 Communication Seminars

Scholars bring special expertise in an area of communication studies to enrich the usual classes.

571 Teaching (2 cr)

An exploration of the students' readiness for the ministry of teaching in Christian faith communities. Emphasis is given to the development of a biblical understanding of the ministry of teaching as well as the acquisition of necessary skills for preparing class syllabus, lesson plans with measurable objectives and desirable outcomes, and evaluation.

572 Christian Education

An introduction to the intentional educational processes in the total life of Christian learning communities. Emphasis is given to the development of an integrated theological and interdisciplinary view of education in a Christian leaning community.

573 Advanced Teaching

An examination of the teaching/learning process in Christian education context. Emphasis is given to the development of quality teaching through preparation, presentation, assessment, and evaluation of lessons.

574 Teaching Practicum

Advanced students may opt for an experiment in teaching in a Christian learning community under the supervision of a faculty. Attention is given to the professional, emotional, and spiritual development of the student in the context of a teaching ministry.

575 Christian Education Seminar

Scholars bring special expertise in an area of Christian Education studies that enriches the usual classes.

PASTORAL COUNSELLING (PCM)

500 Character Development (2 cr)

A class dealing with the various stages of character development. It provides the students with a means of evaluating their spiritual and emotional development, as well as the tools and skills to monitor and facilitate Christian growth and character.

501 Personal Assessment (2 cr)

A class designed to enable participants to better understand their interests, personalities, gifts, abilities, dispositions, and temperaments in order to identify and implement their personal growth and development.

502 Basic Pastoral Counselling (2 cr)

An introductory counselling class. It provides an overview of pastoral counselling, considering biblical principles and social sciences in developing basic counselling skills. Students are equipped with relevant skills in counselling through active participation from an integrated biblical perspective.

503 Counselling Theory (2 cr)

This class is designed to examine various Christian and secular counselling modalities, and to examine why problems develop, and how they can be dealt with in appropriate and effective ways from a biblical viewpoint.

504 Counselling Methods and Techniques

This class is designed to acquaint students with the breadth and scope of pastoral counselling. It provides an integrated approach to counselling, considering biblical principles, and social sciences in developing competent counselling skills. Students will develop an understanding of the biblical and social science approach to counselling. They will study some major techniques and strategies that can be appropriately and effectively used in counselling individuals. It includes ways of defining the problem and approaches for rendering help.

505 Crisis Counselling (2 cr)

This class is designed to show how to recognize the various stages of crisis and the steps to move a person through a crisis. The student will learn a biblical approach to crisis counselling, practice assisting a person in crisis, and be able to use appropriate Scriptures as needed.

506 Mental Health in Ministry (2 cr)

Designed to introduce the student to the various classifications of mental illness and problems that may be encountered in a Christian counselling setting. This class helps acquaint the students with the terminology of psychopathology and guide them in making appropriate referrals to utilize the resources of the body of Christ.

Prerequisite: PCM 504 Counselling Methods and Techniques.

507 Group Counselling (2 cr)

Provides an experience of discovering biblical solutions to life problems in a group setting. Applies God's Word to emotional, spiritual, and relational needs. Small group interaction and discussion are included each week in examining and experiencing God's transforming work.

508 Human Growth and Development (2 cr)

This class examines the stages of normal human development. It explores the relationship between educational and developmental psychology and spiritual development. The emphases will be on human development and its implications to a Christian's growth and development towards maturity.

510 Christian Marriage and Family (2 cr)

A brief but comprehensive study of the major biblical precepts relating to Christian marriage, the family and predominant issues facing the Christian parents. The class is designed to equip the student with the necessary resources to successfully develop his/her marriage and family, and to teach these principles to others.

511 Premarital and Marriage Counselling

Designed to teach Christian premarital counselling and issues often found in pastoral counselling of married couples, with emphasis on biblical perspectives of marriage, the prevention, and intervention and resolution of marital problems and conflicts. Practical techniques and tools will also be provided to prepare couples who are considering marriage. The emphasis will be on the divine design of marriage from the biblical viewpoint.

Prerequisite: PCM 504 Counselling Methods and Techniques.

512 Family Counselling (2 cr)

This class focuses on a biblical counselling approach to common life problems in families and family relationships. It helps you to recognize and understand family dysfunctions, how the various family members relate to one another and why they do so. The student will learn to help each family member understand problem areas, and to bring healing and resolution to the family members.

Prerequisite: PCM 504 Counselling Methods and Techniques.

513 Counselling Practicum

This class provides advice and support to students in their counselling ministry. Emphasis will be on discussing actual cases, and applying biblical truth and appropriate counselling principles to those cases. They will be discussed in a small group setting providing peer supervision and instructor mentoring to help the student describe problems, possible solutions, and steps to resolution in terms that the counsellee can understand.

514 Cross-cultural Counselling (2 cr)

This class examines cross-cultural principles and their application in the pastoral counselling ministry in the Asian context. Participants will learn to be culturally aware and sensitive to others from a different culture.

Prerequisite: PCM 504 Counselling Methods and Techniques.



PERSONNEL

RESIDENT FACULTY

BIBLICAL STUDIES

Dr. Ho Chiao Ek
Principal of EAST

BA, National University of Singapore (Singapore), 1981
MDiv, Talbot School of Theology, Biola University (USA), 1993
PhD, University of Aberdeen (UK), 2000



Dr. Ho, a staff with Singapore Campus Crusade for Christ since 1981, joined the resident faculty of EAST in 2001 and taught Greek exegesis and New Testament courses prior to assuming the role of Director/Principal. He has more than ten years of experience in mentoring student leaders at the National University of Singapore. He has also served as director of Campus Crusade's staff-training centre in Singapore, and led many teams on short-term cross-cultural mission trips. While studying in California, he also served as a pastor to youths and young professionals. He and his wife, Samantha, have two children and the family worships at Bartley Christian Church.

Rev. Dr. Christopher Creech
Lecturer, Chaplain

BSc., Business Administration, University of Colorado (USA),
1971
MDiv., Southwestern Baptist Theological Seminary (USA), 1978
PhD, Southwestern Baptist Theological Seminary, (USA), 1992



Dr. Creech has served as a pastor and church planter for over thirty years in the USA and Toronto, Canada. He has many years of experience as a senior pastor with the Baptist General Conference (USA). He has taught as an adjunct and visiting teacher in seminaries and Bible institutes in Russia, Israel, Brazil, Estonia and the USA. His teaching focus is in the areas of preaching, Biblical interpretation, Biblical background, intercultural studies and pastoral ministry. Dr. Creech and his wife Faith have a married daughter.

Dr. Keith Shubert
Lecturer

BS, Mathematics, Cedarville University (USA), 1967
ThM, Christian Education, Dallas Theological Seminary (USA), 1971
MA, Historical Geography of Ancient Israel, Jerusalem University
College (Israel), 1987
PhD, Bible Exposition, Dallas Theological Seminary (USA), 2000



Dr. Shubert has been on staff with Campus Crusade for Christ (USA) since 1971 and is an ordained minister with the International Baptist Church (Hawaii) since 1978. He has lectured at the International School of Theology (USA) 1981-94, Dallas Theological Seminary, 1996-

2000 and more recently at the International Graduate School of Theology (Philippines), 2002-2009. He has participated in archaeological excavations at Ramat Rachel and Har-Tov in the Holy Land and was nominated by Dallas Seminary faculty and listed in *Who's Who Among American College and University Students* (1996-97). Keith is married to Jeannette, who also joins him as a fellow-lecturer.

Mr. Craig Olson

Lecturer, Dean of Admissions

BE, Chemical Engineering, University of Auckland (New Zealand), 1987

ThM, Academic Ministry, Dallas Theological Seminary, (USA), 2007



Craig Olson, a staff Campus Crusade for Christ since 1987, served in campus ministry in his native New Zealand for 10 years as Campus staff, Campus Director, and Administrator & Trainer for the staff training center (GCTC). He led mission trips of Kiwi students to Thailand and the USA. Since moving to Texas in 1997 he completed his ThM at Dallas Theological Seminary and served as the Asian Translation Coordinator for the Josh McDowell Ministry. In this role he has been responsible for seeing more than half a million Josh McDowell books distributed in six countries in Asia in nine different languages. Craig has been married to Brigitte for 17 years and they have two children.

Mr. Toe Set

Lecturer, Dean of Students

BSc, Computer Science, University of Alberta (Canada), 1985

ThM, Bible Exposition, Dallas Theological Seminary, (USA), 2006



Toe Set, a staff of Campus Crusade for Christ Singapore since 1986, has served on campus in the ministry of evangelism and discipleship, leading mission trips, directing the student ministries on the National University of Singapore campus, and staff training. He went to New Zealand for two years to help set up the staff training center, pioneered new campuses, staff training and development. He spent six years in Myanmar to help set up the staff training center, directed the staff training center and national campus ministry, pioneered new campuses, and led mission trips.

THEOLOGICAL & HISTORICAL STUDIES (THS)

Rev. Lewis Winkler

Lecturer, Registrar

BA, Biological Science, Lawrence University (USA), 1987

MDiv, International School of Theology (USA), 1997

PhD, Fuller Theological Seminary (USA), 2008



An ordained minister of the Evangelical Church Alliance (USA), Rev. Winkler has been a staff member of Campus Crusade for Christ since 1987. He served for six years in the campus ministry at Kansas State University. For four years he did pastoral ministry through a local church, teaching and discipling high school youth, providing leadership in adult education ministries, and preaching and teaching in the church. Lewis was part of a church plant team and a lecturer of systematic theology at the International School of Theology for five years. He has been a visiting teacher at BIOLA University (USA) and is a lecturer with the International School of Leadership providing leadership development for Christian leaders around the world. Rev. Dr. Winkler and his wife Barbara have three children.

INTER-CULTURAL STUDIES (ICS)

Rev. Dr. Richard L. Langston

Lecturer, Assoc. Dean of Academics

BSc, Oklahoma State University (USA), 1968
MDiv, International School of Theology (USA), 1981
DMiss, Trinity Evangelical Divinity School (USA), 1989



Rev. Dr. Langston was a pioneering director who helped to start EAST in 1992 and has been actively involved in various leadership positions at EAST. He teaches courses in missions, spiritual warfare, and church growth. Called to serve the Lord in Asia after joining Campus Crusade for Christ (USA) in 1967, Rev. Dr. Langston and his wife, Laurel, lived in the Philippines for eight years before coming to Singapore in 1989. They have travelled to teach in many places in Asia since 1973. He is the author of a book entitled *Bribery and the Bible*. The Langstons are regarded as mentoring “parents” to many students at EAST—a testimony to their conviction that theological education must stress the integration of principles with practice in the application of biblical truths in people’s lives. They raised their two children in Asia and have twin grandsons.

Dr. Kwa Kiem Kiok

Lecturer

LLB, University of Singapore (Singapore), 1986
MDiv, Trinity Theological College (Singapore), 1999
PhD, Asbury Theological Seminary (USA), 2007



Kiem Kiok spent 6 years with Graduates’ Christian Fellowship, an affiliate of Fellowship of Evangelical Students, equipping graduates for witness and ministry in the marketplace. From 1999 to 2003, at her home church Trinity Methodist Church, she was involved in training, curriculum development, discipleship and mentoring. While pursuing her doctoral studies she also worked at the International Office at Asbury Theological Seminary. After a brief time to set up a research centre for the National Council of Churches in Singapore, she now joins the EAST faculty. She and her husband Ivan Tan enjoy walking and listening to classical music.

LEADERSHIP, MINISTRY, AND COMMUNICATION (LMC)

Dr. Mah Yeow Beng

Lecturer, Dean of Academics

Dip, Mechanical Engineering, Singapore Polytechnic (Singapore), 1981

DipCS & MDiv, Regent College (Canada), 2003

ThM, Asbury Theological Seminary (USA), 2003

DMin, Asbury Theological Seminary (USA), 2004



Dr. Mah has been on staff with Singapore Campus Crusade for Christ (SCCC) since 1987. He has a passion for church ministry and missions. Before going for his theological studies, he served for more than five years as the Church Resource Ministry Coordinator of SCCC and three and a half years as a missionary to Cambodia. He is married to Elaine and they have three boys, Caleb, David, and Barnabas.

Dr. Roland Tan

Lecturer, Dean of Extension

BSc, University of Singapore (Singapore), 1974

MDiv, International School of Theology-Asia (Philippines), 1984

DMin, Asia Graduate School of Theology (Singapore), 1997



Dr. Roland Tan has been a full-time staff of Singapore Campus Crusade for Christ (SCCC) since 1974. Sending Singapore campus students for short term mission trips was his brainchild (1980). God has also used him to pioneer ministries in Hongkong and Indo-China. He has also lived in and served in the Philippines and South Korea. With the East Asia Area Office from 1987-1996, his responsibilities included Campus, Staff Training (GCTC), New Life Training for churches, Finance, and Personnel. He was the National Director of SCCC from 1996-2006. He is an elder with Bethesda Frankel Estate Church, where he serves as superintendent for the teenagers' Sunday School.

Dr. Tan has been teaching Public Speaking and Biblical Preaching as an adjunct faculty at EAST. He is married to Ying Kheng and they have a daughter, Julienne who was born in Hong Kong.

Jeannette Shubert

Lecturer

BSc, Grace University (USA), 1977

MA, Guidance and Counselling, University of Nebraska-Omaha (USA), 1980

ThM, Academic Ministries – Bible Exposition, Dallas Theological Seminary (USA), 1996

DMin, Christian Education, Dallas Theological Seminary (USA), 2001



Jeannette grew up in Ethiopia and has lived outside the USA for over 30 years. She has been on staff with Campus Crusade for Christ (USA) since 1981. She has lectured at the Nairobi International School of Theology 1981-87, Dallas Theological Seminary, 1998-2000 and

more recently at the International Graduate School of Theology (Philippines), 2002-2009. She was nominated by Dallas Seminary faculty and listed in *Who's Who Among American College and University Students* (1996-97) and by the students and listed in *Who's Who Among America's Teachers* (2002). Jeannette is married to Keith. She enjoys hiking, cross-country skiing, travel, reading, writing, classical music, cooking, and hospitality.

ADJUNCT FACULTY

BIBLICAL & LANGUAGE STUDIES

Dr. Leong Tien Fock

Staff, Malaysia Campus Crusade for Christ

BEng, University of Malaya (Malaysia), 1981
MA, Wheaton College Graduate School (USA), 1989
MA, University of California (USA), 1991
PhD, University of California (USA), 1994

INTERCULTURAL STUDIES

Dr. Ng Tjoh Dju

Staff, Singapore Campus Crusade for Christ

BSc, University of Singapore (Singapore), 1976
DipEd, Singapore Institute of Education (Singapore), 1977
MDiv, International School of Theology - Asia (Philippines), 1988
PhD, School of Intercultural Studies, Biola University (USA), 2000

LEADERSHIP, MINISTRY, AND COMMUNICATION

Rev. Dr. Victor Koh

President Emeritus of EAST

BSc, University of Singapore (Singapore), 1972
MA, International Christian Graduate University/ISOT (USA), 1982
MDiv, International Christian Graduate University/ISOT (USA), 1983
MA, Ohio State University (USA), 1985
PhD, Ohio State University (USA), 1986

Dr. Robert Singleton

International Travelling Faculty, Orlando Institute

BSc, University of Texas (USA), 1974
ThM, Dallas Theological Seminary (USA), 1977
PhD, University of Texas (USA), 1993

Dr. Hebert Tan

Director of Family Ministry, Emmanuel Methodist Church, Malaysia.

BSc, University of Malaya (Malaysia), 1982

MDiv, Trinity Evangelical Divinity School (USA), 1990

PhD, Northwestern University (USA), 1994

PASTORAL COUNSELLING

Ms. Luda L. Leinster

Marriage and Family Therapist, Genesis Counselling Service (USA)

BA, Houghton College (USA), 1968

MS, California State University (USA), 1994

Dr. Harold Robers

Clinical Psychologist & Counsellor, PsyCare (Singapore)

BA Econ and Sociology, Singapore University (Singapore), 1977

MA Counselling, Denver Seminary (USA), 1987

MA Clinical Psychology, Rosemead School of Psychology, Biola University (USA), 1989

PhD Clinical Psychology, Rosemead School of Psychology, Biola University (USA), 1992

THEOLOGICAL & HISTORICAL STUDIES

Dr. John R. Albrektson

Associate Professor, International School of Leadership

BSc, Duke University (USA), 1970

MDiv, International School of Theology-Asia (Philippines), 1985

ThD, Asia Baptist Graduate Theological Seminary (Philippines), 1994

STAFF

Mr. Benson Goh	Administration Manager
Mr. Peter Lee	Administration Assistant
Mrs. Koh Aitee	Admissions & Liaison Officer
Mrs. Julie Chua	Chief Librarian
Mrs. Magdalene Set	Coordinator, English for Seminarians
Ms. Jaclyn Ng	Finance Officer
Ms. Sylvia Chong	Hospitality
Ms. Malarkody	Librarian
Mrs. Tan Ying Kheng	Publications
Ms. Wong Ee Yuing	Registrar Assistant



APPENDICES

APPENDIX 1: EAST ASIA SCHOOL OF THEOLOGY

DOCTRINAL STATEMENT

The sole basis of our beliefs is the Bible, God's infallible written Word, the 66 books of the Old and New Testaments. We believe that it was uniquely, verbally, and fully inspired by the Holy Spirit and that it was written without error (inerrant) in the original manuscripts. It is the supreme and final authority in all matters on which it speaks.

We accept those large areas of doctrinal teaching on which, historically, there has been general agreement among all true Christians. Because of the specialized calling of our movement, we desire to allow for freedom of conviction on other doctrinal matters, provided that any interpretation is based upon the Bible alone and that no such interpretation shall become an issue which hinders the ministry to which God has called us.

We explicitly affirm our belief in basic Bible teaching as follows:

1. There is one true God, eternally existing in three persons—Father, Son, and Holy Spirit—each of whom possesses equally all the attributes of deity and the characteristics of personality. Deuteronomy 6:4; Matthew 28:18; John 1:1-3, 18; Acts 5:3-4.
2. Jesus Christ is God, the living Word, who became flesh through His miraculous conception by the Holy Spirit and His virgin birth. Hence, He is perfect deity and true humanity united in one person forever. Matthew 1:18-25; Luke 1:30-37; John 1:1,14; Philippians 2:6-11; Colossians 2:9.
3. He lived a sinless life and voluntarily atoned for the sins of men by dying on the cross as their substitute, thus satisfying divine justice and accomplishing salvation for all who trust in Him alone. John 10:17-18; Romans 3:24-26; 2 Corinthians 5:21; 1 Peter 3:18; 1 John 3:5; 4:10.
4. He rose from the dead in the same body, though glorified, in which He had lived and died. John 20:24-29; Luke 24:36-43; 1 Corinthians 15:4, 14.
5. He ascended bodily into heaven and sat down at the right hand of God the Father where He, the only mediator between God and man, continually makes intercession for His own. Acts 1:9-11; Ephesians 1:20; 1 Timothy 2:5; Hebrews 7:24-25; 1 John 2:1-2.
6. Man was originally created in the image of God. He sinned by disobeying God; thus, he was alienated from his Creator. That historic fall brought all mankind under divine condemnation. Genesis 1:26-27; 2:15-17; 3:1-24; Romans 5:12-21; 1 Corinthians 15:21-22.
7. Man's nature is corrupted and he is thus totally unable to please God. Every man is in need of regeneration and renewal by the Holy Spirit. Mark 7:20-23; John 3:1-21; Romans 3:9-20; Ephesians 2:1-7; Titus 3:5-7.
8. The salvation of man is wholly a work of God's free grace and is not the work, in whole or in part, of human works of goodness or religious ceremony. God imputes His righteousness to those who put their faith in Christ alone for their salvation and thereby justifies them in His sight. Romans 3:21-26; 9:30-33; Galatians 3:1-14; 22-24; Ephesians 2:8-10.

9. It is the privilege of all who are born again of the Spirit to be assured of their salvation from the very moment in which they trust Christ as their Saviour. This assurance is not based upon any kind of human merit but is produced by the witness of the Holy Spirit who confirms in the believer the testimony of God in His written Word. John 1:12; Romans 8:14-17; 1 Thessalonians 1:5; 1 John 5:9-13.
10. The Holy Spirit has come into the world to reveal and glorify Christ and to apply the saving work of Christ to men. He convicts and draws sinners to Christ, imparts new life to them, continually indwells them from the moment of spiritual birth, and seals them until the day of redemption. His fullness, power, and control are appropriated in the believer's life by faith. John 3:5-8; 16:7-15; Romans 8:2-4, 9; 1 Corinthians 6:19; Galatians 3:2-3; Ephesians 1:13-14; 4:30; Titus 3:5.
11. Every believer is called to live in the power of the indwelling Spirit so that he will not fulfil the lust of the flesh but will bear fruit to the glory of God. Galatians 5:16-25; Ephesians 5:18.
12. Jesus Christ is the Head of the Church, His Body, which is composed of all men, living and dead, who have been joined to Him through saving faith. Ephesians 1:22-23; 5:23-32; Colossians 1:18; 1 Thessalonians 4:13-18.
13. God admonishes His people to assemble together regularly for worship, for participation in ordinances, for edification through the Scriptures, and for mutual encouragement. Acts 2:42; 20:7; 1 Corinthians 12:20-28; 16:1-2; Ephesians 4:11-16; 1 Timothy 4:13; 2 Timothy 3:16; 4:2; Hebrews 10:23-25.
14. At physical death the believer enters immediately into eternal, conscious fellowship with the Lord and awaits the resurrection of his body to everlasting glory and blessing. Luke 23:39-43; 1 Corinthians 15:12-58; 2 Corinthians 5:8; Philippians 1:23-24; 3:21; 1 Thessalonians 4:13-18; 1 John 3:2.
15. At physical death the unbeliever enters immediately into eternal, conscious separation from the Lord and awaits the resurrection of his body to everlasting judgement and condemnation. Matthew 13:40-43; Luke 16:19-31; John 5:23-29; Revelation 20:10-15.
16. Jesus Christ will come again to the earth—personally, visibly, and bodily—to consummate history and the eternal plan of God. Acts 1:9-11; 3:19-21; Revelation 19:1-22; 21.
17. The Lord Jesus commanded all believers to proclaim the Gospel throughout the world and to disciple men of every nation. The fulfilment of the Great Commission requires that all worldly and personal ambitions be subordinated to a total commitment to “Him who loved us and gave Himself for us.” Matthew 28:18-20; Mark 16:15-16; Luke 24:46-49; Acts 1:7-8; Romans 12:1-2; Galatians 2:19-20; Philippians 3:7-21.

APPENDIX 2: Estimated Cost of Programme for Full-time Students

Course Title	Duration (Years)	Number of Credits	Total Amount of Fees (inclusive of GST)
Master of Divinity	3	143	\$10,163
Master of Arts	2	93	\$6,773
Graduate Certificate	1	30	\$2,426
Bachelor of Arts	2	127	\$7,583
English for Seminarians	6 months	24	\$1,740

The above estimation takes into consideration the following:

- 1) One time application fee.
- 2) Full tuition fees
 - a. Assuming no transfer of credits, no add/drop/change/withdraw and late registration/payment fees incurred).
 - b. In the case of the Bachelor of Arts programme, it assumes that the student is able to take 40 of the 127 credits as foundational credits.
- 3) Quarterly registration fee.
- 4) Quarterly Orientation/Student activity fee.

APPENDIX 3: SCHOOL CALENDAR 2009-20010

The school calendar follows this pattern, although the exact dates vary from year to year.

1ST QUARTER 2009

15-26 June 2009	Intensive Classes	
29 June-3 July 2009	Orientation – New students on Tues & Wed – All students on Thursday	Week 0
6 July 2009	Classes begin / Late registration	Week 1
5-13 Sept 2009	Mid-Term Break	Week 10
14 Sept 2009	Classes resume	Week 11
22-25 Sept 2009	Final Exams	Week 12
26 Sept-4 Oct 2009	Term Vacation	Week 13

2ND QUARTER 2009-10

5 Oct 2009	Classes begin / Late registration	Week 1
7- 11 Dec 2009	Make up classes or regular classes	Week 10
12Dec 2009- 3 Jan 2010	Christmas Break	Week 11-13
4 Jan 2010	Classes resume or make up classes	Week 14
11-15 Jan 2010	Final Exams	Week 15
16-24 Jan 2010	Term Vacation	Week 16

3RD QUARTER 2010

25 Jan 2010	Classes begin / Late registration	Week 1
13-21 Feb 2010	Chinese New Year Break	Week 4
22 Feb 2010	Classes resume	Week 5
13-21 Mar 2010	Mid-Term Break	Week 8
22 Mar 2010	Classes resume	Week 9
26 Apr- 30 Apr 2010	Final Exams	Week 14
8 May 2010	Commencement	Week 15
9 May- 27 June 2010	Year-End Vacation	Week 16- 22
11-23 May 2010	Holy Land Study Trip	Week 16-17
14- 25 June 2010	Intensive Classes	Week 21-22

PUBLIC HOLIDAYS - observed

National Day	Monday 10 Aug 2009*
Hari Raya Puasa	Monday 21 Sept 2009*
Deepavali	Saturday 17 October 2009
Hari Raya Haji	Friday 27 Nov 2009
Christmas Day	Friday 25 Dec 2009
New Year's Day	Friday 1 Jan 2010
Chinese New Year	<i>Sunday-Monday 14-16 Feb 2010*</i>
Good Friday	Friday 2 April 2010
Labour Day	Saturday 1 May 2010
Vesak Day	<i>Friday 28 May 2010</i>

* Official Holiday on Sunday, but observed on Monday

As of 3 Mar. 2009



1 Dorset Road
Singapore 219486
Tel: 6291 9744 Fax: 6299 5040

E-mail: eastinfo@east.edu.sg
www.east.edu.sg

A Division of Campus Crusade Asia Limited (197200238N)
5th revision: June 2009